

INVICTA

CE

EN

DIRECTIONS FOR INSTALLATION USE AND MAINTENANCE

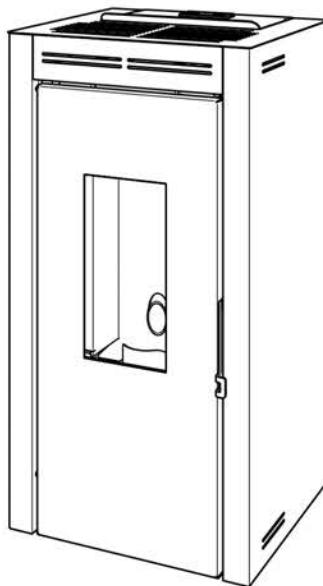

TERAMO 17 PLUS

ENVIRONMENT-FRIENDLY PELLET STOVE
WATER HEATING
TIGHT AND VENTILATED

**THESE INSTRUCTIONS ARE INTEGRAL PART OF THE PRODUCT
PLEASE READ CAREFULLY AND SAVE FOR FUTURE REFERENCE**

Serial number

Foreword

- **Congratulations on your purchase of a INVICTA product, one of the best available on the market!**
- Before installing and operating your appliance, read this instruction manual carefully and save it for future reference.
- All installation, water and electrical connection, inspection, maintenance and repair work must be performed by authorized and qualified technicians only.
- The INVICTA pellet stoves and their claddings are distributed in France through a network of dealers-installers. INVICTA does not allow the installation of its own appliances carried out by private customers.
- It is recommended that the first-time lighting of your appliance should be done by the appliance installer who may check and ensure proper appliance operation and draught.
- The technician must present a certificate verifying proper installation.
- If the water heating appliance is to be installed and connected to an existing system, first verify the compatibility of the various parts of the system.
- This appliance can be used by children aged 8 years or older and by people with reduced physical, sensory or mental capabilities or without experience or knowledge, if adequately supervised or if instructions relating to the use of the appliance in complete safety have been delivered to them and whether the associated risks have been perceived.



WARNING: All cleaning of the various parts must be done when the appliance is completely cold and disconnected from the electrical power source. Cleaning and maintenance operations to be carried out by the user cannot be done by unattended children.

- Never let your appliance unattended in the presence of children. Do not let the children touch any hot surface areas of the appliance nor let them operate it.



Overpressure in the combustion chamber preceded by a significant and anomalous presence of smoke without flames is the most serious problem to be monitored closely because it can lead to rupture of the glass or cause the appliance door to burst open with the consequent release of smoke into the room. (Refer also to heading 1.5.2).



If the appliance repeatedly fails to light or in the presence of repeated anomalous generation of copious amounts of smoke with no flame in the combustion chamber, stop using the appliance immediately and have both appliance and flue checked by an authorised technician.

- For any further information or requests always contact an authorized dealer who will be pleased to assist you.

Symbols used in this manual

In the present instruction manual some indications are pointed out by the following symbols:



Safety precautions.



Prohibited operation.



Important information.

INVICTA (hereinafter referred to as the "MANUFACTURER" assumes no responsibility for any incidental or consequential damage to people, things or pets resulting from the inobservance of the prescriptions given in this manual, particularly of those marked with following symbols.



| | |
|---|-----------|
| SUMMARY | 4 |
| 1 GENERAL INFORMATION | 4 |
| 1.1 Warranty | 4 |
| 1.1.1 Warranty conditions | 4 |
| 1.1.2 CE label and product serial number | 8 |
| 1.1.3 Remarks on materials | 9 |
| 1.1.4 null | 9 |
| 1.2 Certifications | 10 |
| 1.2.1 CE marking information | 10 |
| 1.2.2 Ecodesign 2022 | 11 |
| 1.2.3 Further certifications | 12 |
| 1.3 Technical dimensions and features | 12 |
| 1.3.1 Technical drawings stove | 12 |
| 1.3.2 Technical features | 13 |
| 1.4 Pellet fuel | 14 |
| 1.5 Recommendations | 15 |
| 1.5.1 Safety precautions | 15 |
| 1.5.2 Warnings for the management of anomalies in the combustion chamber | 16 |
| 1.5.3 General recommendations | 17 |
| 1.5.4 End-of-life disposal of appliance components | 18 |
| 1.6 Safety requirements and devices | 20 |
| 1.7 Environment requirements | 21 |
| 1.8 Equipment | 22 |
| 1.9 Functioning principle | 23 |
| 2 INSTALLATION | 24 |
| 2.1 Packaging dismantling and disposal | 24 |
| 2.2 Installation requirements | 24 |
| 2.3 Appliance installation | 24 |
| 2.3.1 Appliance Positioning | 24 |
| 2.3.2 Outside air intake | 26 |
| 2.3.3 Flue gases venting into a traditional chimney | 27 |
| 2.3.4 Smoke outlet into exterior vertical vent (stainless steel lined type) | 28 |
| 2.3.5 Disassembling the cladding | 29 |
| 2.3.6 Electrical connection | 31 |
| 2.3.7 Plumbing connection | 31 |
| 2.3.8 Filling the system | 32 |
| 2.3.9 Sample Installation Schematic | 33 |
| 3 OPERATION | 34 |
| 3.1 Pre- and first-lighting instructions | 34 |
| 3.2 Pellet loading | 34 |
| 3.3 Control panel | 35 |
| 3.3.1 Ignition | 36 |
| 3.3.2 Extinguishing | 37 |
| 3.3.3 Maximum operating power set adjustment | 37 |
| 3.3.4 Ambient temperature set adjustment | 38 |

| | |
|---|-----------|
| 3.3.5 Set water temperature | 38 |
| 3.3.6 Set fan | 39 |
| 3.3.7 Menu | 39 |
| 3.3.8 Alarm signals | 45 |
| 3.3.9 SERVICE signal | 46 |
| 4 CARE AND MAINTENANCE | 47 |
| 4.1 Recurrent maintenance | 47 |
| 4.1.1 Cleaning of display screen and exterior cladding elements | 47 |
| 4.1.2 Cleaning of ceramic glass | 47 |
| 4.1.3 Recurrent maintenance of type A | 48 |
| 4.2 Routine maintenance | 50 |
| 4.2.1 Routine maintenance of type B | 50 |
| 4.2.2 Routine maintenance of type C | 53 |
| 4.2.3 Gasket control | 53 |
| 4.2.4 Cleaning of vertical venting pipes | 53 |
| 4.3 Putting your appliance out of service | 54 |
| 4.4 Failures/ Causes / Trouble-shooting | 54 |
| 4.4.1 Replacement of fuse in service | 55 |
| 5 FOR THE AUTHORIZED SERVICE TECHNICIAN | 56 |
| 5.1 Wiring-diagram | 56 |
| 5.1.1 Terminal block for output devices | 57 |
| 5.2 Connection to a thermostat or to a switch | 57 |
| 5.3 Spare parts list | 58 |
| 5.4 Servicing record | 59 |

1 GENERAL INFORMATION

1.1 Warranty

1.1.1 Warranty conditions

The marketed Products comply with regulations applicable in France and their performances are compatible with non-professional uses.

Non-professional consumer Customers (hereinafter "Consumers") automatically benefit from the legal guarantee of conformity and the legal guarantee against hidden defects free of charge.

In addition, and independently of the legal guarantees, they benefit from a commercial guarantee.

A. Legal guarantees

A.1 Legal guarantee of conformity

INVICTA GROUP undertakes to deliver the Consumer goods that comply with the contractual description and the criteria set out in Article L217-5 of the French Consumer Code.

It is liable for non-conformities existing at the time the Products are delivered and which appear within two years of the delivery.

This guarantee period applies without prejudice to Articles 2224 et seq. of the French Civil Code, with the prescription period starting to run on the day the Consumer becomes aware of the non-conformity.

Non-conformities which appear within a period of twenty-four months from the delivery of the Products are, unless proven otherwise, considered to have existed at the time of delivery.

If a non-conformity is found, Consumers may demand that the delivered Products be made compliant by repair or replacement, failing which the price can be reduced or the sale be cancelled in accordance with the legal conditions.

They may also suspend the payment of all or part of the price or the remittance of the benefit provided for in the contract until INVICTA GROUP has met its obligations under the legal guarantee of conformity under articles 1219 and 1220 of the French Civil Code.

It is up to the Consumer to request the upgrade to conformity from INVICTA GROUP by choosing between repair and replacement. The goods must be brought into conformity within a period not exceeding thirty days following the Consumer's request.

Proof of purchase of the Product (invoice, detailed sales receipt) and photos of the product will be required for the processing of any claim.

The repair or replacement of the non-compliant Product includes, where applicable, the removal and return of the Product and the installation of the repaired or replaced Product.

Any Product brought into conformity as part of the legal guarantee of conformity benefits from a six-month extension of this guarantee.

If the non-compliant Product has been replaced because, despite the Consumer's choice, INVICTA GROUP has not brought the Product into conformity, the replacement will reinitialise the legal guarantee of conformity period starting from the delivery of the replaced Product.

If the requested upgrade to compliance is impossible or entails disproportionate costs under the conditions provided for in Article L 217-12 of the French Consumer Code, INVICTA GROUP may refuse it. If the conditions provided for in article L 217-12 of the French Consumer Code are not met, the Consumer may, after formal notice, pursue the forced execution in kind of the solution initially requested in accordance with articles 1221 et seq. of the French Civil Code.

Finally, the Consumer may demand a price reduction or the cancellation of the sale (unless the non-conformity is minor) in the cases provided for by Article L 217-14 of the French Consumer Code.

When the non-conformity is so serious that it justifies a reduction in price or the immediate cancellation of the sale, the Consumer is not required to request the repair or replacement of the non-compliant Product first.

The price reduction is proportional to the difference between the value of the delivered Product and the value of the Product without the non-conformity.

If the sale is cancelled, the Consumer will be refunded the price paid after the return of the non-compliant Products to INVICTA GROUP, at the latter's expense.

The refund is made on receipt of the non-compliant Product or proof of its shipment by the Consumer and at the latest within the following fourteen days by means of the same payment method as the one used by the Consumer at the time of payment, unless the latter expressly agrees otherwise and in any case without any additional costs.

The above mentioned provisions are without prejudice to the possible award of damages to the Consumer for the loss suffered by the latter as a result of the non-conformity.

A.2 Legal guarantee against hidden defects

INVICTA GROUP is liable to the Consumer for hidden defects as part of the legal guarantee against hidden defects resulting from a material, design or manufacturing defect impacting the delivered products and rendering them unfit for purpose. The Consumer may decide to implement the guarantee against hidden defects for the Products in accordance with Article 1641 of the French Civil Code; in that case, they may choose between the cancellation of the sale or a reduction of the sale price in accordance with Article 1644 of the French Civil Code.

A.3 Exclusion of legal guarantees

INVICTA GROUP cannot be held liable in the following cases:

- Non-compliance with the legislation of the country in which the Products are delivered, which it is the Consumer's responsibility to check before placing the order,
- Misuse, professional use, negligence or lack of maintenance by the Consumer, as well as in case of normal wear and tear of the Product, accident or force majeure.

B. Commercial guarantee applicable to Consumers

In addition to the aforementioned legal guarantee of conformity and against hidden defects, INVICTA GROUP offers a commercial guarantee reserved for Consumers (excluding all professional Clients) (hereinafter the "Commercial Guarantee"), subject to full payment of the invoice corresponding to the Product by the aforementioned Consumer, under the conditions and according to the durations described below.

In accordance with Article D.217-3 of the French Consumer Code, the insert attached to Article D.211-2 of the French Consumer Code is reproduced below, restating the main provisions of the legal guarantee of conformity:

The consumer has two years from the delivery of the goods to obtain the implementation of the legal guarantee of conformity if a non-conformity appears. During that period, the consumer is only required to prove the existence of the non-conformity and not the date it appeared.

When the contract for the sale of the goods provides for the supply of digital content or a digital service on a continuous basis for a period of more than two years, the legal guarantee applies to that digital content or digital service throughout the planned period of supply. During that period, the consumer is only required to prove the existence of the non-conformity of the digital content or service and not the date of its appearance.

The legal guarantee of conformity entails an obligation on the part of the professional, where applicable, to provide any updates needed to maintain the conformity of the goods.

The legal guarantee of conformity gives consumers the right to the repair or replacement of the goods within thirty days of their request, free of charge and without any major inconvenience to them.

If the goods are repaired under the legal guarantee of conformity, the consumer benefits from a six-month extension of the initial guarantee.

If the consumer requests the goods to be repaired but the vendor imposes replacement, the legal guarantee of conformity is renewed for a period of two years from the date the goods are replaced.

The consumer may obtain a reduction in the purchase price by keeping the goods or terminate the contract and obtain a full refund against the return of the goods, if:

1° The professional refuses to repair or replace the goods;

2° The repair or replacement of the good occurs after a period of thirty days;

3° The repair or replacement of the goods causes major inconvenience to the consumer, in particular where the consumer definitively bears the cost of the return or removal of the non-compliant goods, or if they bear the cost of installing the repaired or replaced goods;

4° The non-conformity of the goods persists despite the vendor's unsuccessful attempt to bring it to conformity.

The consumer is also entitled to a reduction in the price of the goods or to the termination of the contract when the non-conformity is so serious as to justify the immediate reduction in price or termination of the contract. The consumer is then not required to request the repair or replacement of the goods beforehand.

The consumer is not entitled to cancel the sale if the non-conformity is minor.

Any period of immobilisation of the goods for the purpose of repair or replacement suspends the guarantee that was still running until the delivery of the repaired goods.

The rights mentioned above result from the application of Articles L. 217-1 to L. 217-32 of the French Consumer Code.

A vendor who obstructs the implementation of the legal guarantee of conformity in bad faith is liable to a civil fine of up to EUR 300,000, which may be increased to 10% of the average annual turnover (Article L. 241-5 of the French Consumer Code).

The consumer also benefits from the legal guarantee against hidden defects under articles 1641 to 1649 of the French Civil Code for a period of two years from the discovery of the defect. This guarantee gives the right to a price reduction if the goods are kept or to a full refund in return for the return of the goods.

B.1 Territoriality

The Commercial Guarantee applies in all countries in which the Products are sold by INVICTA GROUP.

B.2 Content and duration

The Commercial Guarantee only applies to the following Products, excluding all others.

Heating appliances

At the end of the twenty-four (24) month period mentioned in article A.1 above, the heating elements (non-removable parts) are

guaranteed to Consumers, depending on the type of heating appliance they have purchased and according to the following periods:

- For the heating elements of wood burning stoves, fireplaces, inserts and ranges:

The Commercial Guarantee for these products will have a maximum duration of three (3) years, which will begin at the end of the twenty-four (24) month period mentioned in article A.1 above. In all cases, the Commercial Guarantee for these products will end on the fifth anniversary of the purchase of the product by the Consumer.

- For the heating elements of pellet stoves, fireplaces and inserts:

The Commercial Guarantee will only apply if the Products have been installed in a compliant manner and subject to verification of such compliance by the network of INVICTA GROUP authorised technical stations within 3 months of purchase. The Commercial Guarantee for these products will have a maximum duration of one (1) year, which will begin at the end of the twenty-four (24) month period mentioned in article A.1 above. In all cases, the Commercial Guarantee on these products will end on the third anniversary of the purchase of the product by the Consumer.

The Commercial Guarantee is limited to the free replacement of recognised defective parts after inspection by INVICTA GROUP. If the replacement of these parts proves too expensive, INVICTA GROUP may decide to replace the Product. Under no circumstances may INVICTA GROUP be the subject of a claim for damages, under any name or form whatsoever.

The costs of travel, transport, labour, packaging, dismantling and the consequences of immobilisation of the equipment resulting from guarantee operations, are borne by the Consumer.

The following heating appliance components are expressly excluded from the Commercial Guarantee:

- External removable parts,
- Normal wear and tear of the Product such as, for example, a change in appearance (colour, gloss) or corrosion, as well as of the steel of cast iron moving or fixed internal parts of the Product,
- The consequences of improper maintenance or lack of maintenance of the Product, an accident, negligence or error in handling the Product and, more generally, failure to comply with instructions for use and maintenance and, in particular, maintenance by qualified personnel,
- Since the glass withstands a temperature of 750°C and the temperatures in the combustion chamber never reach this temperature, there can be no breakage of the glazing due to overheating. As a result, glass breakage due to improper handling during use or handling of the appliance is not covered by the Commercial Guarantee,
- Seals for any heating appliance, crucibles for pellet stoves and spark plugs for pellet stoves and gas heaters are considered to be wear parts,
- As the fuel used and the operation of the appliance are beyond the manufacturer's control,
- The parts of the fireplace in direct or indirect contact with the igniting fuel, such as:
 - Decorative plates, fire grates, deflectors, hearth log protections, inserts, wood stoves and hydros marketed under the INVICTA or DEVILLE brands,
 - Decorative plates and deflectors for pellet stoves marketed under the INVICTA, or DEVILLE brands,
 - Diffuser tubes, wicks, igniters, cast iron rings for stoves marketed under the INVICTA, or DEVILLE brand names,
 - Refractory bricks, fire grates, deflectors for wood burning ranges marketed under the INVICTA, or DEVILLE brand names,
 - Decorative plates and deflectors for gas heating appliances marketed under the INVICTA, or DEVILLE brands.
- The electrical parts (extractor, fan, electronic board) of pellet stoves marketed under the INVICTA or DEVILLE brands are only covered by the Legal Guarantee.
- The other components, such as:
 - Latches, screws, fans, printed circuits, switches, terminals, electric wires, fireplace electric ducts, inserts, wood stoves marketed under the INVICTA or DEVILLE brands,
 - Latches, screws, decorative plates, deflectors for pellet stoves marketed under the INVICTA or DEVILLE brands,
 - Handles, screws, bricks, thermometers for wood burning ranges marketed under the INVICTA, or DEVILLE brand names.

The following are also excluded from the Commercial Guarantee:

- Any damage caused by mechanical or electrical components that are not supplied by the manufacturer of the Product and/or are prohibited by laws governing heating appliances.
- Damage caused by any use other than that intended for the Product concerned, in particular the use of any unauthorised fuels.

The Commercial Guarantee applies to any defect in material or manufacturing, subject to the non-professional, reasonable use of the appliance in accordance with the operating instructions provided with the appliance and any applicable regulations.

INVICTA GROUP is released from any obligation relating to the Commercial Guarantee in the event of Product installations that are not compliant with any legal, regulatory and/or administrative requirements and trade practices, or if the Product is altered.

The Commercial Guarantee does not cover any damage, whether total or partial, direct or indirect, caused by use that does not comply with the instructions for use and/or maintenance, is abnormal, negligent or incorrect, or results from a cause unrelated to the intrinsic qualities of the Product.

This Commercial Guarantee is excluded for professional use of the Product.

Proof of Product purchase (invoice, detailed sales receipt) and photos will be requested for the processing of any claims under the Legal Guarantee or the above mentioned contractual guarantee.

The Contractual Guarantee is only valid if the appliance has been installed at the address indicated on the guarantee certificate provided with the appliance and if the purchaser has registered the Product on the www.invicta.fr website or by calling the toll-free number 0.809.10.00.13 within 3 months of the purchase, it being specified that in all cases, the Consumer is required to

provide proof of purchase of the Product for the implementation of the Contractual Guarantee.

B.3 Transfer of the guarantee

The Commercial Guarantee is linked to the Product sold by INVICTA GROUP, it is automatically acquired by any new non-professional owner consumer for the remaining duration.

B.4 Price of the guarantee

The Commercial Guarantee as defined above does not entail any additional payment by the Consumer.

B.5 Immobilisation of the Product

Any period of immobilisation of the Product suspends the remaining guarantee period from the date of the Customer's request for intervention or from the date the Product is made available for replacement or repair if this starting point is more favourable to the Customer. The duration will also be suspended in the event of negotiations between the guarantor and the Customer with a view to an amicable settlement of the dispute.

B.6 Amicable settlement of disputes

In the event of difficulty in applying this guarantee, the Consumer has the possibility, before any legal action, to seek an amicable solution, in particular by contacting INVICTA GROUP's After-Sales Service.

1.1.2 CE label and product serial number

The serial number is printed on the cover of the appliance "installation, use and maintenance" manual. It is highly recommended that the serial number be quoted for any request.

This number is also printed at the bottom of the CE label located on the back side of the unit.

| | | | | | |
|--|--|---|--|---|-------------------|
| | | | | INVICTA Zone Industrielle Lieu-dit "La Gravette" F-08350 DONCHERY - FRANCE | |
| APPAREIL DE CHAUFFAGE DOMESTIQUE, ALIMENTÉ À GRANULÉS DE BOIS • RESIDENTIAL SPACE HEATING APPLIANCES, FIRED BY WOOD PELLETS • RAUMHEIZER ZUR VERFEUERUNG, VON HOLZPELLETS • APPARECCHI PER IL RISCALDAMENTO DOMESTICO, ALIMENTATI CON PELLETTI DI LEGNO | | | | | |
| N = P.T. Nominale / Nominal T.O. / NW Leistung / P.T. Nominale R = P.T. Minimale / Minimum T.O. / Min. Leistung / P.T. Ridotta | | | | | |
| Puissance Thermique Nominale / Thermal Output | | | | N | kW |
| WL=Wärmeleistung / Potenza Termica | | | | R | |
| P.T. utile transférée à l'air / useful T.O. to room | | | | N | kW |
| WL an den Raum / P.T. utile resa all'aria | | | | R | |
| P.T. utile transférée à l'eau / useful T.O. to water | | | | N | kW |
| WL an das Wasser / P.T. utile resa all'acqua | | | | R | |
| Émission CO (mesure à 13% O ₂) / CO emission (at 13% O ₂) | | | | N | % |
| CO Emission (bei 13% O ₂) / CO misurato (al 13% di O ₂) | | | | R | |
| Valeur moyenne poussières (à 13% O ₂) / Average dust content (at 13% O ₂) | | | | N | mg/m ³ |
| Mittlerer Staubgehalt (bei 13% O ₂) / Valore medio polveri (al 13% di O ₂) | | | | R | |
| Température fumées en aval de la buse / Flue gas outlet temperature | | | | N | °C |
| Abgasstemperatur hinter Abgasstutzen / Temperatura dei fumi allo scarico | | | | R | |
| Rendement / Efficiency / Wirkungsgrad / Rendimento | | | | N | % |
| Rendement / Efficiency / Wirkungsgrad / Rendimento | | | | R | |
| Pression max. de l'eau admise en fonction | | | | | bar |
| Max. water pressure admitted during operation / maximaler Betriebsdruck | | | | | |
| Massima pressione idrica di esercizio ammessa | | | | | |
| Puissance électrique nominale / Nominal electrical output | | | | | W |
| Elektrische Nennleistung / Potenza elettrica nominale | | | | | |
| Tension nominale / Nominal voltage / Nennspannung / Tensione nominale | | | | | V |
| Fréquence nominale / Nominal frequency / Nennfrequenz / Frequenza nominale | | | | | Hz |
| Combustible / Fuel / Brennstoff / Combustibile | | GRANULÉS DE BOIS / WOODPELLET HOLZPELLET / PELLETTI DI LEGNO | | | |
| Distance minimum des matériaux inflammables | | | | R = | |
| Minimum distance from inflammable materials | | | | L = | |
| Mindestabstand zu brennbaren Materialien | | | | B = | |
| Distanza minima da materiali infiammabili | | | | | |
| SE CONFORMER AUX INSTRUCTIONS D'UTILISATION / READ AND FOLLOW THE OPERATING INSTRUCTIONS BEDIENUNGSANLEITUNG LESEN UND BEACHTEN / LEGGERE E SEGUIRE LE ISTRUZIONI PER L'UTILIZZO UTILISER UNIQUEMENT LES COMBUSTIBLES RECOMMANDÉS / USE ONLY RECOMMENDED FUELS / VERWENDUNG AUSSCHLIEßLICH EMPFOHLENER BRENNSTOFFE / UTILIZZARE SOLO I COMBUSTIBILI RACCOMANDATI CET APPAREIL NE PEUT PAS ÊTRE UTILISÉ SUR UN CONDUIT DE FUMÉE À USAGE COLLECTIF/ THIS APPLIANCE CANNOT BE USED ON A MULTI-FLUE CHIMNEY / DAS GERÄT DARF NICHT AN MEHRFACHBELEGTEM SCHORNSTEIN ANGESCHLOSSEN WERDEN / QUESTO APPARECCHIO NON PUÒ ESSERE USATO SU CANNA FUMARIA CONDIVISA | | | | | |
| Designed in Italy - Made in Italy | | | | | |
| N° DE SÉRIE | | 000000 000000 | | SERIAL NO. | |
| SERIENNUMMER | | | | N° DI SERIE | |

Example of CE label with serial number

1.1.3 Remarks on materials



The materials used to manufacture this product have been thoroughly checked and are guaranteed to be free from defects.

The components below are subject to common wear and tear (corrosion or progressive decay) that cannot constitute grounds for objection due to the type and features of the materials used in the construction of the parts and due to the product operational conditions.

- The internal movable or fix parts in steel or cast iron: are made of high temperature resistant materials but could distort and settle if using the wrong fuel or exceeding the fuel amount suggested in this manual. However they can eventually present rusty or oxidized parts.
- The burn pots may be subject to high overheating, and with the time can be subject to corrosion and distortion or oxidation.
- The turbulators may be subject to high overheating, and with the time can be subject to corrosion and distortion or oxidation.
- Gaskets: are necessary to make the firebox airtight.

Misuse of the following components could result in their breakage.

- The ceramic glass panels: are thoroughly factory-checked. Please note that with the techniques currently available, the manufacturing of glass ceramic panels totally free from any kind of defects cannot be guaranteed and therefore any irregularities that might be noticed have to be considered within the specifications of this material and are not prejudicial to its strength nor to the correct functioning of the firebox. Note: Please refer to section 4.1.2 for directions on cleaning.

1.2 Certifications

1.2.1 CE marking information



CE-MARKING INFORMATION

| | |
|---|--|
| CE | |
| INVICTA | |
| 24 | |
| EN 14785:2006 | |
| Home-heating appliance fired by wood pellets | |
| TERAMO 17 PLUS | |
| Security minimum distance from inflammable material | : side 200 back 200 |
| CO-emission in combustion products (13% O₂) | : 0,0038 % nominal thermal output 0,0045 % minimum output |
| Max. water pressure admitted during operation | : 3bar |
| Flue gas temperature | : 98 °C nominal thermal output 59 °C minimum output |
| Nominal thermal output | : 17,2kW |
| Useful thermal output | : 3,2 kW output to room 14,0 kW output to water |
| Minimal thermal output | : 7,6kW |
| Efficiency | : 94,3% nominal thermal output 96,1% minimum output |
| Type of fuel | : wood pellets |
| Nominal power | : 380W |
| Nominal voltage | : 230V |
| Nominal frequency | : 50Hz |

INVICTA GROUP
 Directeur Technique Groupe
Fabio Simonetto

INVICTA GROUP - Zone Industrielle Lieu-dit « la Gravette » - 08350 DONCHERY - Tél. 03 24 27 71 71 - Fax 03 24 26 62 42 - Site : www.invicta.fr
SASU au capital de 4.866.450 € - Code APE 2752Z - Siren 785.520.180 RCS SEDAN - TVA intracommunautaire FR 66.785.520.180

1.2.2 Ecodesign 2022



Language: ENG

INFORMATION REQUIREMENTS FOR SOLID FUEL LOCAL SPACE HEATER

| | |
|--------------------|-----------------------|
| Trademark: | INVICTA |
| Product type: | - |
| Model: | TERAMO 17 PLUS |
| Equivalent models: | - |

| | |
|---------------------------------|---|
| Indirect heating functionality: | <input checked="" type="checkbox"/> yes |
| Direct heat output: | 3,2 kW |
| Indirect heat output: | 14,0 kW |

| Fuels | Preferred fuel [yes / no] | Other suitable fuel(s) [yes / no] | η_s [%] | Space heating emissions at nominal heat output | | | | Space heating emissions at minimum heat output | | | |
|--|---|---|-----------------|---|-----|----|-----|---|-----|----|-----|
| | | | | PM | OGC | CO | NOX | PM | OGC | CO | NOX |
| | | | | mg/Nm ³ (13%O ₂) | | | | mg/Nm ³ (13%O ₂) | | | |
| Compressed wood in the form of pellets or briquettes | <input checked="" type="checkbox"/> yes | <input checked="" type="checkbox"/> no | 91% | 15 | 2 | 48 | 99 | 19 | 1 | 56 | 94 |
| Energy efficiency class: | A++ | | | | | | | | | | |
| Energy efficiency index (EEI): | 133 | | | | | | | | | | |

CHARACTERISTICS WHEN OPERATING WITH THE PREFERRED FUEL ONLY:

| HEAT OUTPUT | | | |
|----------------------------------|-----------|------|----|
| Nominal heat output | P_{nom} | 17,2 | kW |
| Minimum heat output (indicative) | P_{min} | 7,6 | kW |

| USEFUL EFFICIENCY (NCV as received) | | | |
|---|-----------------|------|---|
| Useful efficiency at nominal heat output | $\eta_{th,nom}$ | 94,3 | % |
| Useful efficiency at minimum heat output (indicative) | $\eta_{th,min}$ | 96,1 | % |

| AUXILIARY ELECTRICITY CONSUMPTION | | | |
|-----------------------------------|-------------|-------|----|
| At rated heat output | $e_{l,max}$ | 0,055 | kW |
| At minimum heat output | $e_{l,min}$ | 0,046 | kW |
| In standby mode | $e_{l,sb}$ | 0,003 | kW |

| PERMANENT PILOT FLAME POWER REQUIREMENTS | | | |
|---|-------------|------|----|
| Pilot flame power requirement (if applicable) | P_{pilot} | N.a. | kW |

| TYPE OF HEAT OUTPUT or ROOM TEMPERATURE CONTROL | | |
|--|------|----|
| With electronic room temperature control plus week timer | (F2) | 7% |

| OTHER CONTROL OPTIONS | | |
|-----------------------|------|----|
| Not applicable | (F3) | 0% |

| INFORMATION REGARDS CERTIFICATION LABORATORY AND TEST REPORT | | | |
|--|---|------------|------------|
| Certification laboratory: | KIWA CERMET ITALIA S.p.A. Via Cadriano, 23, I-40057 GRANAROLO NELL'EMILIA (BO) N.B.: 0476 | | |
| Test report n°: | 3013197 | Issued on: | 28/10/2024 |

Observe the specific precautions for installation, assembly and maintenance indicated in the manual accompanying the product

| CONTACTS | ISSUED ON: | EMPOWERED PERSON: |
|---|------------|--|
| Invicta Group Zone Industrielle Lieu-dit "La Gravette" - 08350 DONCHERY - FR Tél: +33 (0)3 24 27 71 71 www.invicta-group.fr accueil@invicta-group.fr | 29/10/2024 | Ing. Andrea Tezza Technical Manager |

1.2.3 Further certifications

We declare that the appliance
TERAMO 17 PLUS

complies with legislative provisions that implement the following directives and regulations:

- Directive 2011/65/EU (RoHS Directive on the restriction of the use of certain hazardous substances in electrical and electronic equipment).
- Directive 2014/30/EU (EMCD Electromagnetic Compatibility) and subsequent amendments.
- Directive 2014/35/EU (LVD Low Voltage) and subsequent amendments.
- Regulation (UE) 305/2011 (Building Products).

1.3 Technical dimensions and features

1.3.1 Technical drawings stove

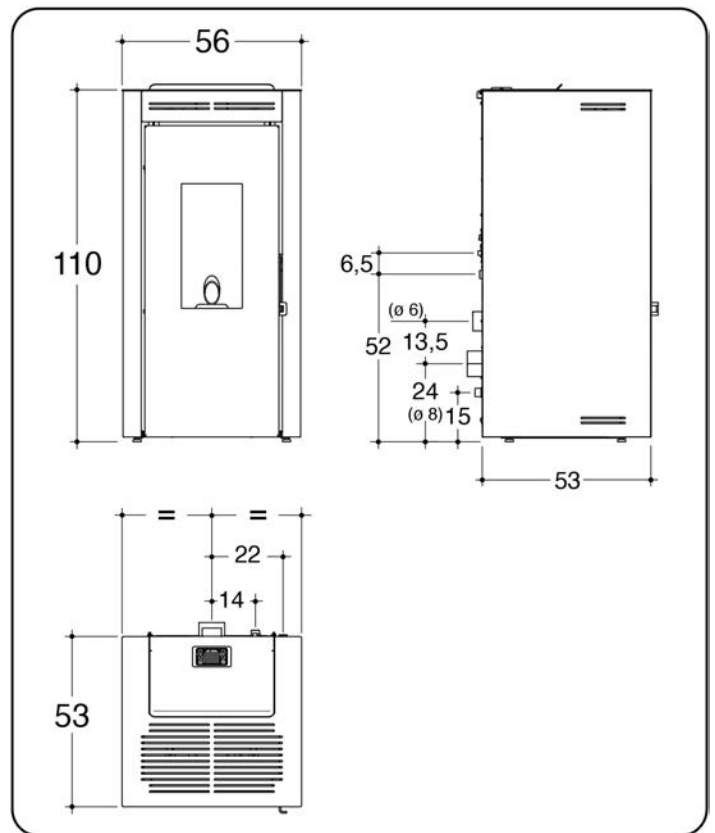
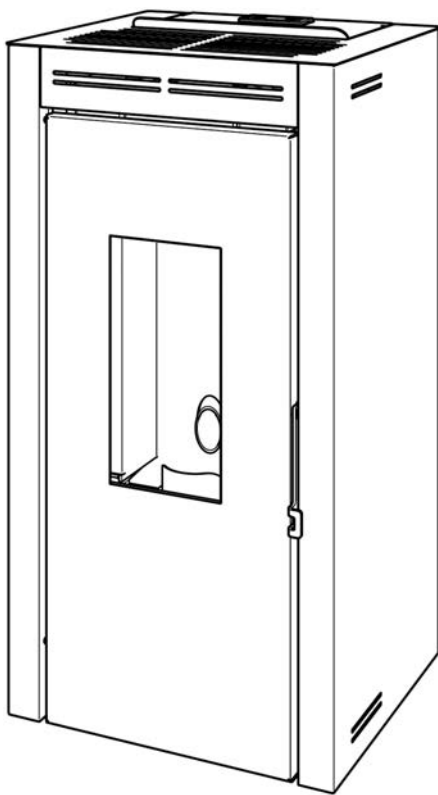

(m) = male - (f) = female

1.3.2 Technical features

| Readings in accordance with standard EN 14785:2006 | TERAMO 17 PLUS | | |
|---|---------------------------------------|---------|----------------|
| Output | nominal | minimum | |
| Thermal Output | 17,2 | 7,6 | kW |
| heat output transferred to room air | 3,2 | 2,3 | kW |
| heat output transferred to water | 14,0 | 5,3 | kW |
| CO emission at 13% oxygen | 0,0038 | 0,0045 | % |
| efficiency | 94,3 | 96,1 | % |
| max. allowable water pressure during operation | 3 | | bar |
| safety valve | 3 | | bar |
| max. delivery temperature | 80 | | °C |
| nominal electrical power | 380 | | W |
| nominal voltage | 230 | | V |
| nominal frequency | 50 | | Hz |
| fuel | wood pellet | | |
| fuel consumption per hour | 3,78 | 1,64 | kg/h |
| total capacity of flue gases | 10,8 | 6,8 | g/s |
| flue gas temperature | 98 | 59 | °C |
| flue gas temperature downstream of the flue spigot/socket | 118 | 71 | °C |
| flue draught pressure | 11 | 12 | Pa |
| expansion tank | closed | | |
| boiler capacity | 27 | | l |
| connections | 3/4 | | " |
| receptacle capacity | 24 | | kg |
| burn time | 6 | 14,5 | h |
| operating power required | 3,2 - 46 - 55 | | W |
| flue gases outlet | Ø 80 | | mm |
| combustion air intake | Ø 60 | | mm |
| minimum distance from flammable materials | side: 200 back: 200 front: 1500 | | mm |
| protection degree IP | IP20 | | |
| heatable area at certified power (*) | 197 | | m ² |
| net weight | 162 | | kg |
| weight with packaging | 177 | | kg |

* The value indicated for heatable area (referred to areas with 2.70 m height with heating requirement between 32 and 33 W/m³) is merely indicative and it is calculated on the basis of perfectly insulated rooms and with the appliance installed in the best position to ensure an even distribution of the thermal flow. Given the countless different installation situations that can be found, the MANUFACTURER does not guarantee the matching of the indicated values in all contexts.

i IMPORTANT (FOR THE TECHNICIAN): When sizing the flues of wood pellet burning appliances using dedicated software applications, you can use a pressure value of 0 Pascal as a reference.

1.4 Pellet fuel

Wood pellets are made through sawdust drawing after processing natural dry wood, whose content of lignin gives compactness to the material and enables to manufacture pellets without using any adhesives or binders.

The section of wood pellets varies from 6 to 12 mm.; the standard length is from 5 to 30 mm.; the density of a high grade pellet fuel varies from 1000 to 1400 kg/cu.m.

i **These airtight stoves are designed to use wood pellets based on sawdust pressed into small logs (called "pellets"), certified to class A1 according to ISO 17225-2, ENplus-A1, DIN Plus or NF 444 category "NF Granulés Biocombustibles Bois Qualité Haute Performance".**

Various types of wood pellets are available on the market and their characteristics depend on the wood mixtures used for their manufacturing.

The pellet fuel produced from natural wood, free of dirt or any other impurities, originally contains an extremely low moisture content, from 6% to 8%, allowing its use without previous seasoning. Mind that the moisture content of pellets can easily change if the fuel is stocked in unsuitable places and that an increase in the moisture content may also increase the size of pellets, which may result in the blockage of the fuel feeding into the burn pot. A rise in the moisture content may also vary the molecular structure of pellets, which may convert into a viscous and low combustible material.

⊘ **It is FORBIDDEN to use fuels other than wood pellet.**

⊘ **The use of pellets manufactured from rejects of semifinished wood products containing binders and paint is FORBIDDEN; these pellets are not included in the category of approved or recommended pellet fuels.**

The heat output of natural pellets can achieve 4600 Kcal/kg and a very high efficiency is ensured when they are used with the suitable appliances.

Pellets are more economical as a fuel than natural gas or oil.

Their smoke emission rate comply with the most stringent European regulations referring to environmental protection, thanks to their peculiar characteristics teamed up with the technical features of this appliance.

Available on the market in 15 kg. bags, pellets can be stocked easily.

i **For the proper and safe operation of this appliance, it is very important that the pellets are stored in a dry place.**

After extensively testing, for the good functioning and efficiency of the appliance the MANUFACTURER highly recommends using fuel of good quality.

Pellets must be made from natural wood sawdust only, free from other materials.















⚠ **ATTENTION: Loading the pellet through the feeding system on the appliance is influenced by the characteristics of the pellet itself. Introducing different supplies of pellets you can find loading differences that can reach 20/25%, which translate into variations in thermal power introduced.**

Therefore it is always advisable to check, at the first ignition and at each change of supply of pellets, over a period of time not less than 6 continuous hours that the combustion does not present a tendency to extinguish or accumulate pellets in the burner (see paragraph 3.3.7).

⚠ **CAUTION: The use of different fuels (maize, nutshells, etc.), low grade pellets or pellets with different sizes than those we recommend, may cause damages to the appliance component parts thus voiding the warranty granted and releasing the manufacturer from any responsibility.**

1.5 Recommendations

1.5.1 Safety precautions

-  **IMPORTANT!!!** For the proper and safe operation of this appliance and the electrical components in it, and in order to prevent any possibility of causing serious injury, the instructions given in this manual must always be followed.
-  **CAUTION:** The installation, electrical and water connections, inspection of proper functioning, maintenance and repair work must be performed by qualified technicians only.
-  **CAUTION:** Do not connect the appliance to the power line before the cladding has been completely installed.
-  **CAUTION:** If there has been a fire in the flue it is necessary to turn the appliance off and call the fire department and check whether the chimney stack and flue pipe have been visibly damaged. Make any repairs before any further use of the combustion system.
-  **ATTENTION:** this appliance **CAN NOT** be installed using a shared chimney flue.
-  **CAUTION:** All national and local regulations and European Standards shall be complied with when installing the appliance.
-  **CAUTION:** All national and local regulations and European Standards shall be complied with when operating the appliance.
-  **CAUTION:** The accident-prevention and safety requirements stated in this manual must be followed carefully.
-  **CAUTION:** This manual must be read and understood in every part, and the use of the controls must be clear before operating the appliance or executing any works on it.
-  **WARNING:** The appliance operation, controls adjustment and programming must be done by adult persons only. Incorrect operation may cause harm, damage and/or malfunctions.
-  **WARNING:** Any tampering or unauthorized replacement of parts of the appliance could cause dangerous situations for the operator's safety, relieving the MANUFACTURER from any civil and criminal liability.
-  **WARNING:** During operation, some of the appliance surface areas may become very hot; we highly recommend not to leave the unit unattended in the presence of children, elderly and disabled people.
-  **Do not touch the glass; the glass provides visibility of the flames and also contributes to the distribution of heat through irradiation, so it reaches very high temperatures.**
-  **WARNING:** It is strictly forbidden to operate the water heating appliance if there is no water in it, or if there is only a partial amount of the recommended water level.
-  **CAUTION:** To avoid possible overheating with consequential shut-down of the appliance, it is FORBIDDEN to cover it with cloths, towels, etc.



ATTENTION: Keep the fuel and inflammable materials at proper distance.



CAUTION: Leaning or hanging on the opened door imprudently, during cleaning operations, could cause the turnover of the appliance; it is therefore advisable not to do so and to take the necessary precautions especially when children, elderly or disabled people are present.



WARNING: Never use flammable liquids (alcohol or petrol) to speed up the lighting of a wood fire: it is extremely dangerous. Alcohol and petrol release highly flammable vapours, which could provoke the risk of burns.



WARNING: Use of the appliance (in areas with beds/couches) during periods dedicated to sleep is forbidden.

1.5.2 Warnings for the management of anomalies in the combustion chamber



Strict compliance with all the instructions for installation (in accordance with statutory legislation), use and maintenance given in this manual is sufficient to ensure correct operation of the appliance and avoid potential problems.



Malfunctions, both minor and serious, are frequently primarily caused by failure to comply with one or more of the prescriptions set down in this manual.



Overpressure in the combustion chamber preceded by a significant and anomalous presence of smoke without flames is the most serious problem to be monitored closely because it can lead to rupture of the glass or cause the appliance door to burst open with the consequent release of smoke into the room.

To avoid this risk, take care to:

- Ensure the burner is always clean before starting the appliance.
- Remove all encrustations and deposits caused by pellets of the incorrect size or of poor quality.
- Empty the burner and clean it thoroughly before attempting to light the appliance after a failed ignition event.
- Never attempt to load pellets into the burner by hand, either before starting the appliance or while it is operating.
- Refit the burner into its location after each maintenance task, removing any residues around the seating surface.
- When the appliance is in operation check for possible pellet accumulations.
- Monitor appliance operation to check for a tendency of the flame to extinguish.
- Remove any accumulations of unburnt pellets in the burner following a failed ignition event or a no pellet alarm, before re-starting the appliance. For safety reasons, never re-load previously removed unburnt pellets into the pellet fuel hopper.

In the presence of pellet accumulations with the anomalous generation of copious smoke without flame, observe the following prescriptions:

- Do not disconnect the appliance from the electrical power supply under any circumstances.
- Do not open the appliance door.
- As a precaution, open the windows of the room in which the appliance is installed in order to provide adequate ventilation.
- Do not stand in front of the appliance. Keep clear of the area until the smoke has been completely dispersed.



If the appliance repeatedly fails to light or in the presence of repeated anomalous generation of copious amounts of smoke with no flame in the combustion chamber, stop using the appliance immediately and have both appliance and flue checked by an authorised technician.



WARNING: It is PROHIBITED to use and try to re-ignite the appliance after a deflagration in the combustion chamber. Only a qualified technician should be contacted to check and repair any damaged parts.

1.5.3 General recommendations



CAUTION: This appliance is intended for the use it has been designed and manufactured for only.



CAUTION: Do not use this unit as a cooker.



ATTENTION: Don't use the appliance as an incinerator.



CAUTION: Do not use the appliance in the case of faults or malfunctions, and if these should occur while it is on, switch it off immediately by pressing the button [P3] for more than three seconds (see section 3.3.2). Only disconnect the appliance from the mains once it has shut down completely (electrical plug disconnected).



In order to avoid releasing smoke in the room, it is FORBIDDEN to operate the appliance with the door open, without the glass panel or with broken glass.



Inspect and clean the exhaust venting system periodically.



Do NOT spray the appliance with water to clean any of its parts.



For repairing, refer to authorized professionals and ask for original replacement parts only.



Keep this instruction manual as an integral part of the product for future reference. It must be supplied together with the unit if this is resold or moved to another place, so as to allow the next user and installer to get acquainted with its operating instructions and requirements. Should the manual be lost or become unreadable, call Caminetti Montegrappa for a new copy.

1.5.4 End-of-life disposal of appliance components

- i** Responsibility for the demolition and the disposal of the appliance lies exclusively with the owner who will have to act in compliance with the regulations in force in his own Country regarding safety, respect and protection of the environment.
 - i** At the end of his useful life the appliance cannot be disposed of together with urban refuse. It can be taken to special waste collection centers provided by local government, or to a dealer providing this service.
 - i** The separate disposal of the appliance (taking it to authorized recycling centres) avoids the possible negative consequences for the environment and human health resulting from inappropriate disposal and allows to recover the materials it is made of, in order to obtain significant energy and resources savings.
 - i** For more information about how to collect electric and electronic equipment and appliances, batteries and accumulators, please contact your local Council or Public Authority competent to issue the relevant permits.
 - i** The abandonment of the appliance in accessible areas is a serious danger to humans and animals. The responsibility for any damage to people and animals always lies with the owner.
 - i** Upon demolition, CE marking, this manual, the declaration of disposal, the manual for installation and other documents relating to this appliance must be preserved. Remember that any registration with the regional land registry should be annulled.
- !** **WARNING: Improper disposal of the appliance by the user implies the application of administrative sanctions provided by law.**

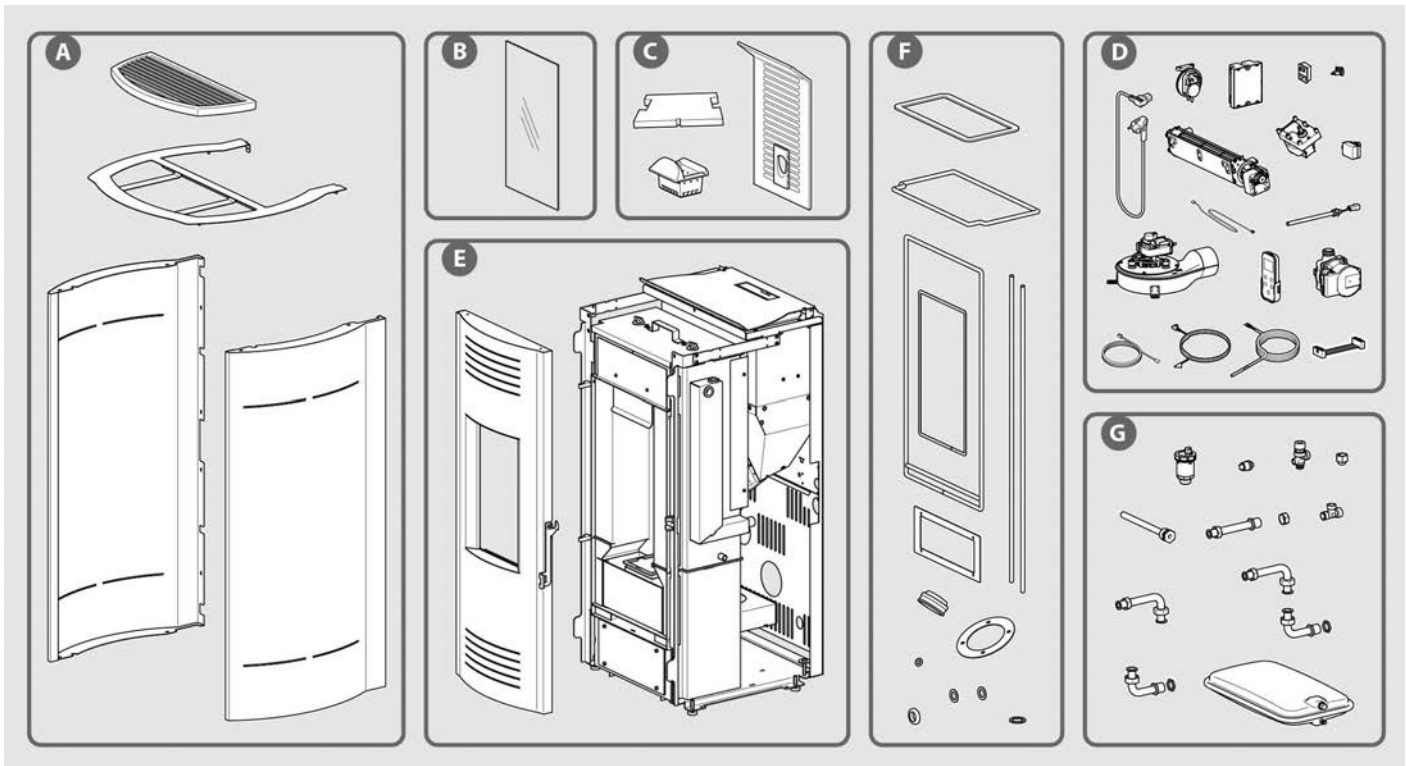

The exploded view and the following table show and list the components of the appliance and the instructions for correct separation and disposal.

In particular, electrical and electronic components must be separated and disposed of at authorized centres according to the WEEE Directive 2012/19/EU.

A. EXTERNAL LINING

If present, dispose of separately according to material:

- metal
- glass
- tiles or ceramic material
- stone

B. DOOR GLASS

If present, dispose of separately in glass recycle containers.

C. INTERNAL LINING

If present, dispose of separately according to material:

- metal
- tiles or ceramic material

D. ELECTRICAL AND ELECTRONIC COMPONENTS

Wiring harnesses, motors, fans, circulating devices, displays, sensors, spark plugs, electronic boards.

Dispose of separately at authorized centres, according to the indications of the WEEE Directive 2012/19/EU.

E. METAL STRUCTURE

Dispose of separately in metal recycle containers.

F. NON-RECYCLABLE COMPONENTS

Handles, Gaskets and piping made of rubber, silicone or fibres, etc.

Dispose of in mixed waste.

G. HYDRAULIC COMPONENTS

Pipes, fittings, expansion vessel, valves.

If present, dispose of separately according to material:

- copper
- brass
- steel
- other materials

Information for management of electric and electronic appliance waste containing batteries or accumulators in accordance with European Directive 2012/19/EC.

i This symbol, which is used on the product, batteries, accumulators or on the packaging or documents, means that at the end of its useful life, this product, the batteries and the accumulators included must not be collected, recycled or disposed of together with domestic waste.

i Improper management of electric or electronic waste or batteries or accumulators can lead to the leakage of hazardous substances contained in the product. For the purpose of preventing damage to health or the environment, users are kindly asked to separate this equipment and/or batteries or accumulators included from other types of waste and to arrange for disposal by the municipal waste service. It is possible to ask your local dealer to collect the waste electric or electronic appliance under the conditions and following the methods provided by national laws transposing the Directive 2012/19/EC.

i Separate waste collection and recycling of unused electric and electronic equipment, batteries and accumulators helps to save natural resources and to guarantee that this waste is processed in a manner that is safe for health and the environment.

i For more information about how to collect electric and electronic equipment and appliances, batteries and accumulators, please contact your local Council or Public Authority competent to issue the relevant permits.

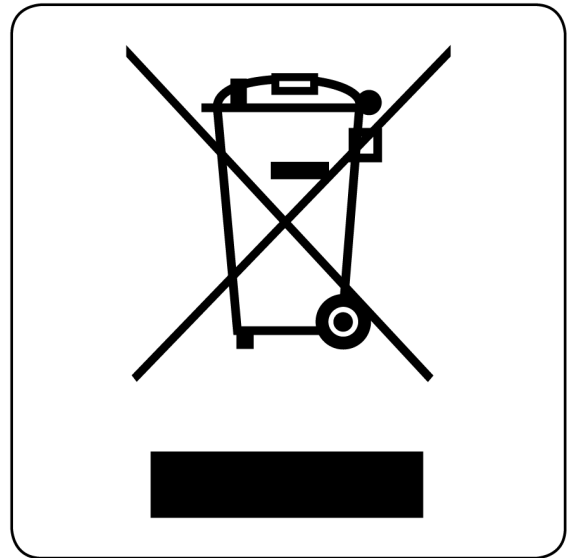

1.6 Safety requirements and devices

Appliance with automatic feed (for closed expansion tank system).

The appliance is provided with the following safety devices:

- Sensor for measuring the flue gas temperature: it indicates that ignition has taken place; it switches on the convection fan; it indicates the unprogrammed fire extinction; it stops the smoke exhauster and the convection fan after the programmed fire extinction.
- Pressure switch to control the negative pressure inside the combustion chamber: switches the appliance off, if it is switched on, or prevents it from being switched on, if it is switched off, whenever the door of the combustion chamber is open or the inspection openings for maintenance work are open, if the cover of the filling aperture is open; It also triggers in the case of an overpressure in the smoke exhauster flue or a negative pressure in the room where the appliance is installed to prevent the flame from being sucked out of the combustion chamber towards the pellet hopper, thus preventing the fuel contained therein from catching fire.
- Safety valve calibrated at 3 bar.
- Stop Fuel-Feed Thermostat (with manual reset).
- Closed expansion tank (6 liter capacity), sized according to the boiler water volume. Preloading pressure 1,5 bar.
- Anti-shutdown circulating pump appliance: function which activates the circulating pump of the appliance for one minute should it remain stationary for a long period.
- Antifreeze device: this function activates the appliance's circulating pump if the temperature of the flow water becomes too low.
- STAND BY safety device: this function switches off the appliance if the temperature of the flow water becomes too high.
- The following functions are controlled by the electronic control unit:
 - Circulation pump start up thermostat.
 - Acoustic alarm activation thermostat.
 - Acoustic alarm.
 - Temperature gauge
 - Pressure gauge.
 - Automatic heat output control device.



It is FORBIDDEN to disconnect the safety devices.

Once the troubles that activated the safety alarms are eliminated, the appliance can be re-started and operated normally.



IMPORTANT: The appliance must be positioned so as to allow easy access to the plug.



WARNING: The appliance must be connected to an insulated flue of the correct size.



NOTE: This section has been drawn up considering the appliance as being operated in accordance with the requirements and directions on the appliance use indicated under chapter 3.

If the appliance is not used in the conditions described in this instruction manual, the MANUFACTURER declines all responsibility for damage to persons, things and animals that may occur. The MANUFACTURER also disclaims any liability for damage to persons, property and animals caused by failure to comply with the following recommendations:

A) During any maintenance, adjusting, cleaning and servicing works, the appliance must not be left unattended in order to avoid incidental starting by third party.

B) Do not mishandle and/or remove any safety devices in the appliance.

C) Provide an efficient connection to the exhaust venting system.

D) Check that the room where the appliance is installed is aerated as prescribed.

1.7 Environment requirements



IMPORTANT: To ensure its proper operation, the appliance shall be located in a ventilated room where an air flow allowing the complete combustion of wood can be admitted according to the installation requirements under the local standards currently in force.

The air supply must be sufficient for proper combustion and to provide ventilation of the room, the volume of which cannot be less than 20 cu.m.

The natural admission of air must be provided through a permanent opening made on the exterior wall(s) of the room to be aired (for the minimum section dimensions see section 2.3.2); the outside fresh air intakes must be made in such a way they can never be obstructed (check regularly).

Air entering the room where the appliance is installed from contiguous room(s) is permitted provided it is admitted from a space which is aired directly from outside, a space which is not used as a bedroom or a bathroom and where fire ignition could never occur, as in a garage or in a combustible warehouse, in compliance with the requirements under the local standards currently in force.

40 cu.m/h of air is required in order to ensure proper fuel combustion.



It is FORBIDDEN to install the appliances in rooms where the depression measured between the internal and external environment is greater than 4 Pa. The possibility of coexistence with devices such as extractor hoods, mechanical ventilation systems, further generators of heat, must be evaluated in the harshest operating conditions both during preventive checks and during the ignition test phase.

A greater than 4 Pa depression inside the room where the appliance is installed may cause the flame to be drawn from the combustion chamber towards the pellet tank, with the consequent risk of a fire inside the tank itself.



If the appliance operates in the presence of depression inside the room in which it is installed, caused by the operation of devices such as hoods, mechanical ventilation systems or other generators, during the pellet loading phase the flame is sucked through the tank which can cause distillation of the pellets and the consequent formation of creosote inside the screw auger.

The occurrence of this phenomenon repeated over time can lead to the blockage of the screw inside the loading system and the consequent malfunction of the heat generator.



The appliance MAY be installed in studio apartment, in a bedroom, in a bathroom, or in any other room where there is another heating appliance (fireplace, stove, etc.), provided the combustion air duct is suitably connected through appropriate outdoor ducts, followed by an inspection of the airtightness of the ducts by qualified personnel.



It is FORBIDDEN to install the appliance near objects made of combustible materials (curtains, pieces of furniture, carpets,...).

If the appliance is installed on flooring that may be flammable, a 2 mm thick (minimum) non-flammable floor protector must be laid underneath that is larger than the unit's base.



The appliance is not designed to be operated in environments where materials may explode. Therefore, it is FORBIDDEN the use of the appliance in an explosive atmosphere or in a space where materials or machineries may produce gas or dust emissions in such a quantity they may cause an explosion.



If wall surfaces are not flammable, install appliance at a distance from the back of approx. 10 cm minimum.

If walls have wood paneling or any other flammable surface, there must be 20 cm minimum clearance behind the appliance, and 20 cm to the side. A 150 cm clearance must be maintained from anything, such as furniture, in front of the unit.

It is recommended that particularly delicate objects or pieces of furniture be installed at higher distances than those previously recommended, if you assume they could be damaged by the changes in temperature produced during the appliance operation.

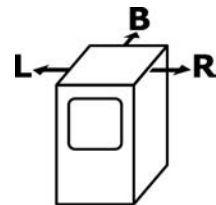

R = 200 mm - L = 200 mm - B = 200 mm

1.8 Equipment



i If the power cable is damaged, it must be replaced with an original one available from the MANUFACTURER or its Technical Assistance Service.

1.9 Functioning principle

This unit has been designed to burn dried, compressed, pelletized wood into a cast-iron container called burn pot where the optimum ratio of combustion air and pellet fuel is always ensured at each heat output that will be selected.

Varying the air supply proportionally to the pellet feed rate ensures the appliance excellent performance at all operating settings and represents an important feature enhancing the quality standards of this appliance. This procedure is handled automatically by the electronic control module: electronic card with microprocessor.

This highly developed module is responsible for controlling and adjusting the appliance functions in accordance with the requirements of the user.

Adjust all combustion parameters: the pellet feed rate, the air intake for combustion, and the outflow of flue gases rate according to the needs of the user, as selected through the appliance programming.

The heat produced in the combustion chamber is transferred to the water inside the boiler through an appropriately proportioned and constructed tube bundle. This structure of the boiler maximizes the heat exchange, thanks also to the turbulators.

To facilitate cleaning, easy access is provided to the flue gases inversion chamber and the tube bundle.

For proper installation, start from the heating system's main collector and connect the delivery and return water pipes to the appliance.

The fan that distributes warm air in the room is the tangential type.

In addition, to ensure ideal functionality, connect the appliance to an efficient, appropriately sized and well-insulated flue gases exhaust system that will keep the flue gases temperature as high as possible in order to attain the necessary draught.

2 INSTALLATION

2.1 Packaging dismantling and disposal

Consisting of non-toxic and not noxious materials, the packaging does not need any special disposal procedure; the user is in charge of stocking, disposing of, or recycling the wastes of the packaging according to the regulations in force in the country where the product has been purchased.

 **WARNING: Keep plastic coverings out of the children's reach as they could represent a danger.**

2.2 Installation requirements

The appliance must be installed in a space which allows to operate it and perform routine maintenance works easily. The room chosen for the installation of the appliance must therefore feature:

- Proper environment conditions and permanent outside air source as indicated under section 1.7 "Environment requirements".
- A floor with proportionate load capacity (see appliance weight in section 1.3.2 of the manual).
- 230 V~ 50 Hz line voltage.
- Electrical system complying with the directives in force.
- Equipped with adequate plumbing connections.
- A system of exhaust gases complying with the standards in force aiming at guaranteeing:
 - Adequate draught for the correct and safe appliance operation.
 - Adequate resistance to high temperatures.
 - Adequate resistance to corrosion due to combustion products.
 - Easy access for periodic checks and maintenance.
 - Adequate insulation from inflammable materials.
 - Adequate drainage of any condensation.
- The room must also comply also with further standards in force in the country where the appliance is installed.

 **CAUTION: Carefully consider the correct sizing of the system, choosing a balanced appliance which matches the actual needs of the system.**

2.3 Appliance installation

 **ATTENTION: The installation of the appliance must be carried out by professional installers only. The MANUFACTURER does not authorize the installation of its appliances carried out by private customers.**

2.3.1 Appliance Positioning

After choosing the most suitable location for your appliance, but before setting it in place, determine the center point of the flue gases outlet pipe (review sections 2.3.3 and 2.3.4 to see which most closely matches your situation), and using the measurements shown in the figure 1, make an access hole through the wall.

See section 2.3.2 for making the outside air intake hole.

 **IMPORTANT: When cutting a hole for the appliance exhaust pipe through a inflammable wall, provide the necessary insulation whose thickness may vary from a minimum of 3 cm up to a maximum of 10 cm. We otherwise recommend the use of lined pipes, which are also excellent for preventing condensation in exterior venting systems.**

 **IMPORTANT: Pressure in the firebox is always negative. There will be a negative pressure in the exhaust pipe when it is connected to an efficient chimney flue as prescribed. The use of pipes and bends with gaskets ensuring airtight connections is recommended.**

 **The installation of your appliance must comply with all prescriptions and recommendations indicated under sections 1.5, 1.6, 1.7 and 2.2, and the electrical plug must be always accessible.**

 **IMPORTANT: All sections of the exhaust venting system must be removable to allow periodical maintenance (see figure 2).**

Note: The schematic shown in the figure n° 2 indicates the necessary configurations for correct appliance operation: height - gradient - inspection access.

The most suitable type of insulation must be determined on a case-by-case basis for each flue gas exhaust venting system, and all external venting systems conduits must be insulated.

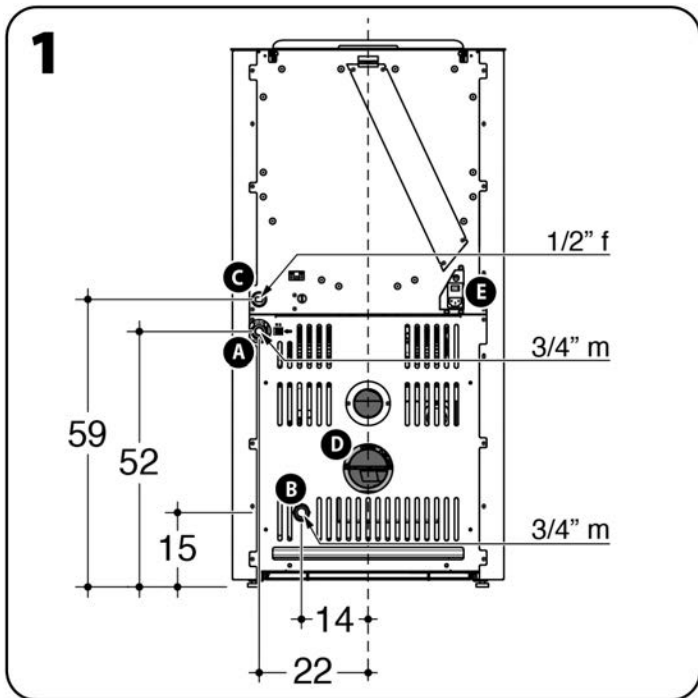

- A. Delivery pipe to system (3/4" m)
 - B. Return pipe to system (3/4" m)
 - C. Heat release safety valve (1/2" f - 3 bar)
 - D. Ø 80 mm flue gases outlet pipe
 - E. Electrical outlet
- (m) = male - (f) = female

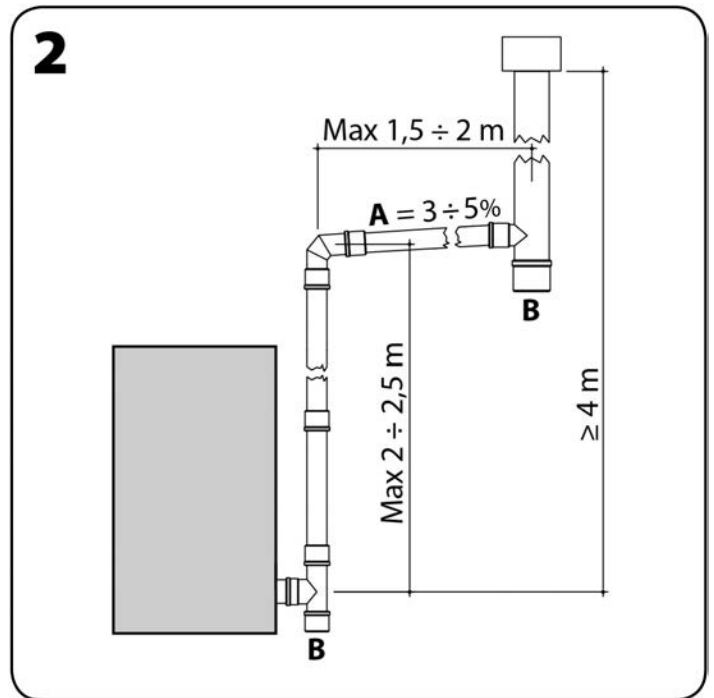

- A. Gradient
- B. Clean-out door

i **IMPORTANT:** Once the appliance has been positioned in the pre-established place, it can be raised by means of the adjustable feet. To adjust the height of the feet (after removing the sides of the cladding - see section 2.3.5) use a 6 mm hex key, screwing clockwise to raise the appliance and unscrewing counter-clockwise to lower it.

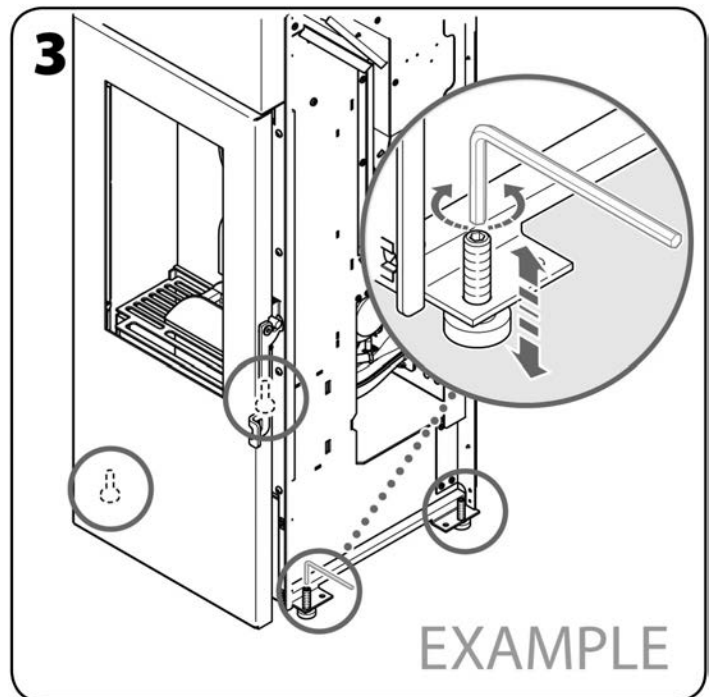

2.3.2 Outside air intake

For health and safety reasons, an outside air supply is recommended. This is also necessary to ensure proper combustion. Cut a hole through an exterior wall for a 100 sq.cm diameter outside air intake (\varnothing 12 cm hole), protected by both an interior and exterior grate.

i The air intake must not be on the back side of the appliance.

! **IMPORTANT:** In the room where the appliance is installed, make sure that there is an air flow rate of 40 cu.m/hour for combustion use.

i This appliance is airtight and is equipped with a primary air intake from outside; it can therefore be installed in low energy households.

The combustion air intake can also be connected directly from the outside:

1. Directly, using a pipe with diameter of 60 mm and maximum length of 3 meters with a protection grate installed on the outside.
2. Using a coaxial smoke venting system that allows the combustion air to be drawn from the space between the internal smoke outlet pipe and the external wall. The unions are supplied by the manufacturers of these systems. This type of installation can be done up to a maximum height of 5 metres with \varnothing 80/125 mm or \varnothing 80/130 mm and up to a height of 10 metres with \varnothing 100/150, in a vertical configuration.

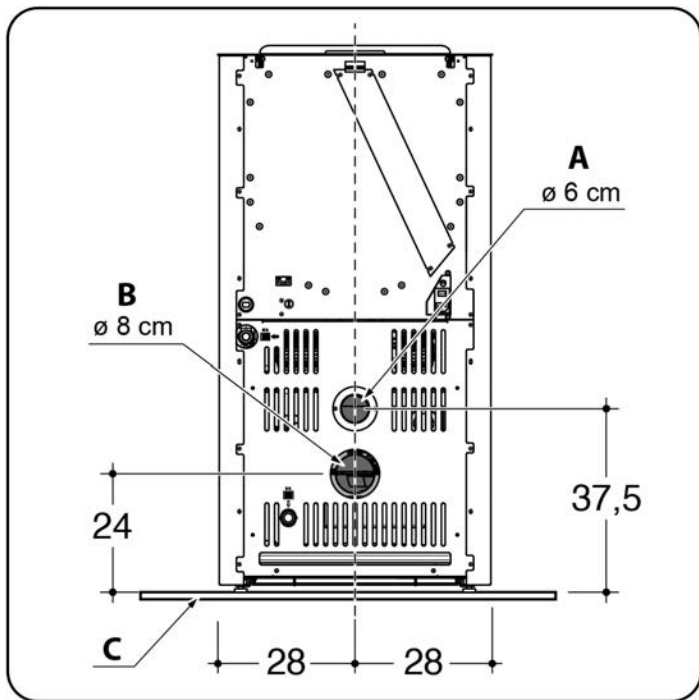

A. Combustion air inlet
B. Smoke outlet

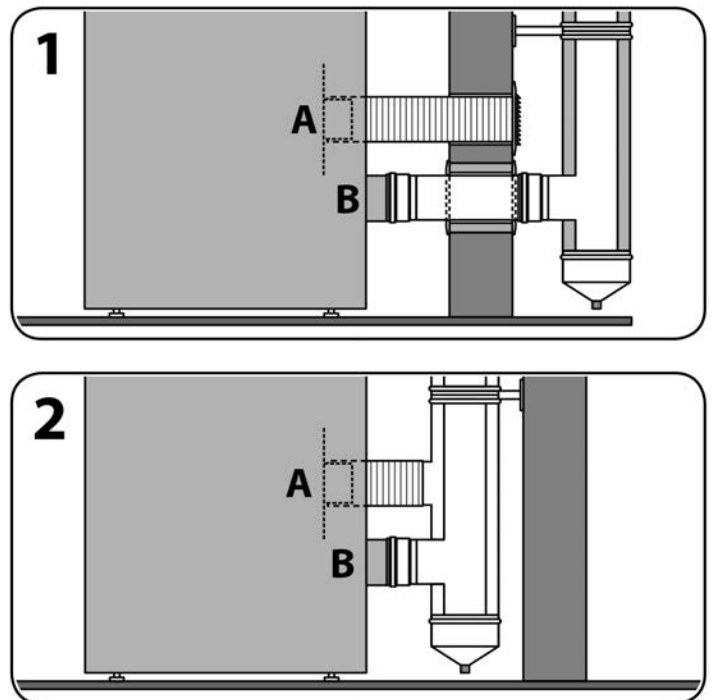

2.3.3 Flue gases venting into a traditional chimney

- The minimum internal dimensions of the chimney flue must be 10x10 cm or 10 cm Ø and must not exceed 20x20 cm or 20 cm Ø; if the existing chimney flue has a larger section or is in poor conditions (i.e. cracked, poor insulation etc.), be sure to refer to a calculation note in order to guarantee that the sizing of the duct allows you to comply with the operating specifications of the appliance and completely safe use.
- Make sure the draught is in Pa, as indicated in the technical chart (see section 1.3.2).
- Provide a clean out door at the bottom of the chimney flue for routine inspection and yearly cleaning.
- The connection of the exhaust pipe to the flue must be sealed or secured with gaskets.
- The chimney flue must be terminated with a wind/rain cap; ensure the wind cap is installed above the top of the roof at a distance "d" varying in accordance with the local standards.

⚠ CAUTION: If there has been a fire in the flue it is necessary to turn the appliance off and call the fire department and check whether the chimney stack and flue pipe have been visibly damaged. Make any repairs before any further use of the combustion system.

i If the smoke exhauster is out of order or in case of electrical outage, the connection of the exhaust pipe into an exterior vertical vent ensures the correct release of combustion gases.

i The draught value indicated among the technical features of the appliance refers to Technical Norms and testing, so as to guarantee the best thermal performances of the appliance (consumption, efficiency, emissions) in conformity with the technical data declared and certified by the Institute in charge of the certification. A higher draught value could provoke malfunctioning, high fuel consumption, overheating of the appliance body and cause annoying noises in the firebox.

i IMPORTANT (FOR THE TECHNICIAN): When sizing the flues of wood pellet burning appliances using dedicated software applications, you can use a pressure value of 0 Pascal as a reference.

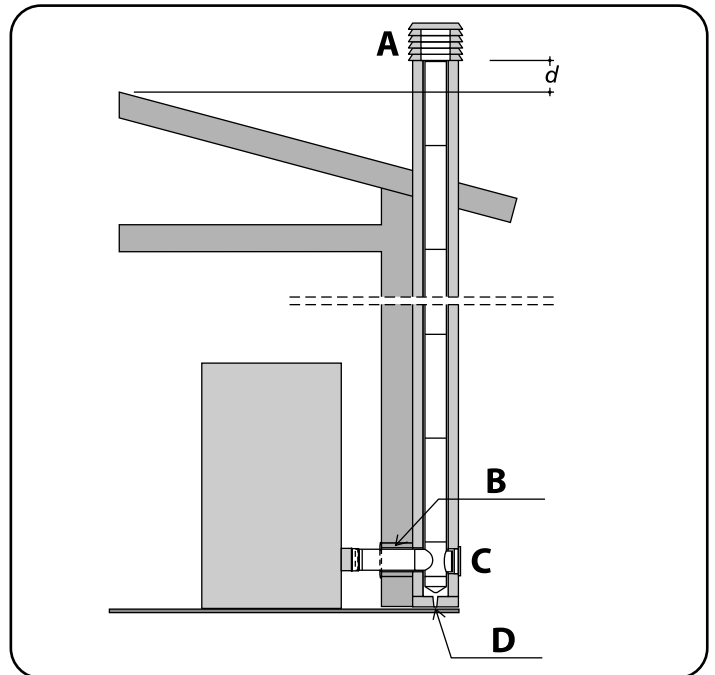

A. CHIMNEY WIND CAP
B. INSULATION
C. CLEAN-OUT DOOR
D. CONDENSATE DRAINAGE SYSTEM

2.3.4 Smoke outlet into exterior vertical vent (stainless steel lined type)

- The internal dimensions of the exterior vertical vent may vary from a min. 10 cm up to a max. 20 cm section.
- Make sure the draught is in Pa, as indicated in the technical chart (see section 1.3.2).
- Only double-wall lined pipes in stainless steel must be used adequately and anchored to the building.
- Provide a clean out door at the bottom of the exterior vertical vent for routine inspection and yearly cleaning.
- The chimney flue must be terminated with a wind/rain cap; ensure the wind cap is installed above the top of the roof at a distance "d" varying in accordance with the local standards.



CAUTION: If there has been a fire in the flue it is necessary to turn the appliance off and call the fire department and check whether the chimney stack and flue pipe have been visibly damaged. Make any repairs before any further use of the combustion system.



If the smoke exhauster is out of order or in case of electrical outage, the connection of the exhaust pipe into an exterior vertical vent ensures the correct release of combustion gases.



The draught value indicated among the technical features of the appliance refers to Technical Norms and testing, so as to guarantee the best thermal performances of the appliance (consumption, efficiency, emissions) in conformity with the technical data declared and certified by the Institute in charge of the certification. A higher draught value could provoke malfunctioning, high fuel consumption, overheating of the appliance body and cause annoying noises in the firebox.



IMPORTANT (FOR THE TECHNICIAN): When sizing the flues of wood pellet burning appliances using dedicated software applications, you can use a pressure value of 0 Pascal as a reference.

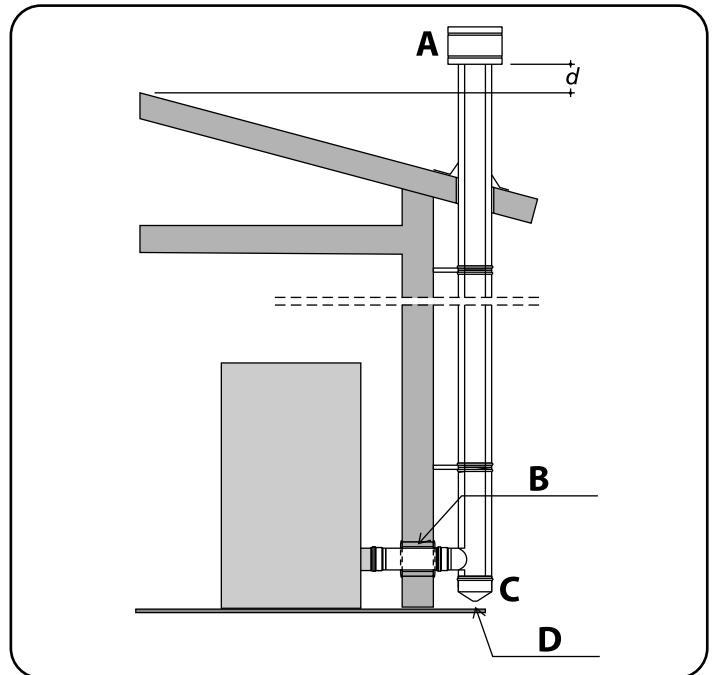

A. CHIMNEY WIND CAP
B. INSULATION
C. CLEAN-OUT DOOR
D. CONDENSATE DRAINAGE SYSTEM

2.3.5 Disassembling the cladding

If it should be necessary, for a maintenance intervention, to access the electrical and electronic parts, operate according to the following instructions to remove the cladding elements.

 **WARNING: This work can only be done after the appliance has cooled completely and has been disconnected from the electrical power source (electrical plug disconnected).**

 **ATTENTION: To be on the safe side, wear work gloves.**

1. Open the pellet loading lid, then carefully lift the upper cladding.
2. Remove the front panel located above the door.
3. Unscrew the 3 rear screws holding the side of the cladding.
4. Unscrew the 2 front fastening screws, then remove the side and move it carefully.

In case the left side must be removed (see image 2):

5. Unscrew the 3 rear screws holding the side of the cladding.
6. Open and remove the door by lifting the 2 pivots.
7. Unscrew the 2 front fastening screws, then remove the side and move it carefully.

 **In the end correctly assemble the component parts removed in reversed sequence.**

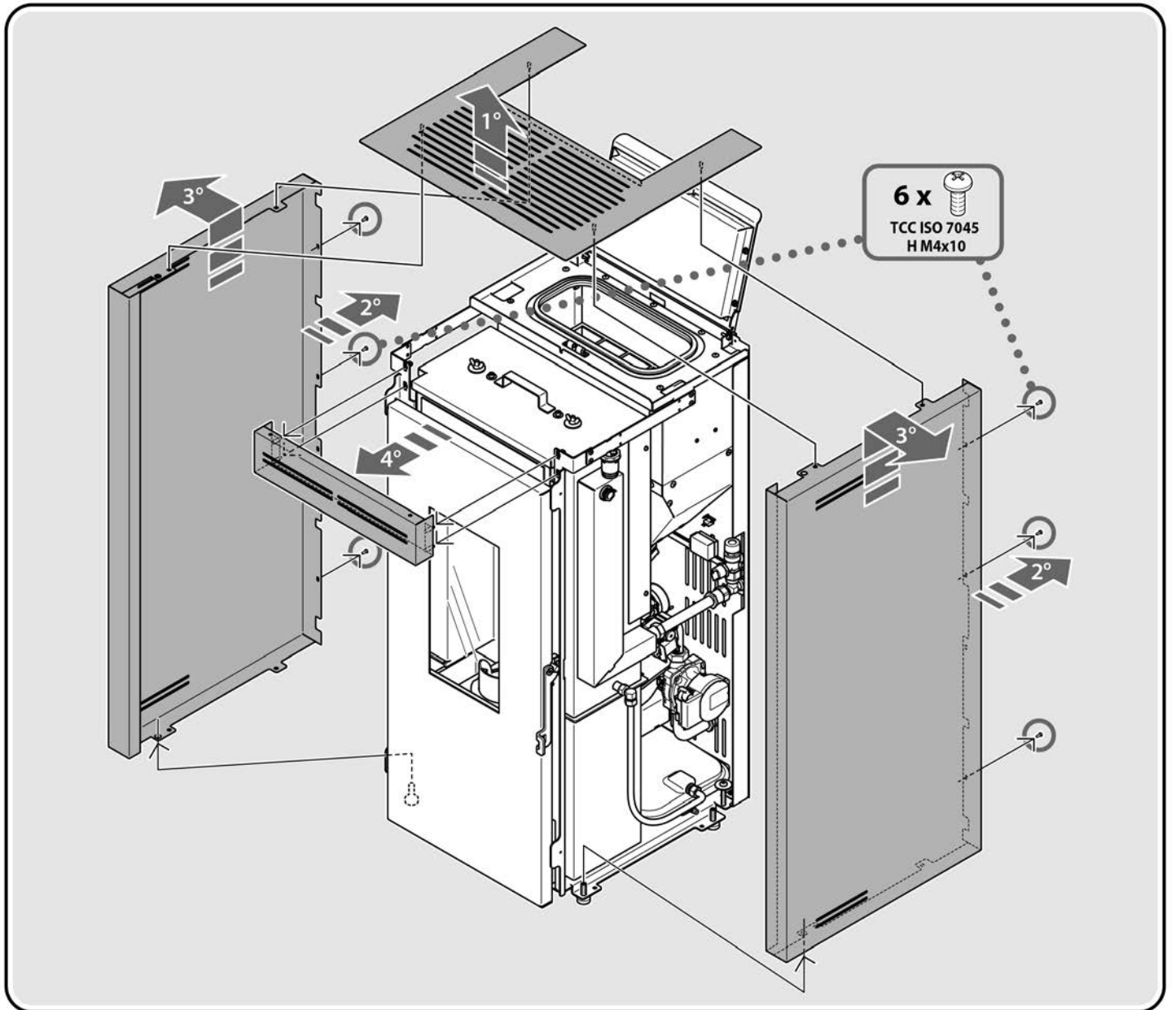

2.3.6 Electrical connection

To be done after installing the cladding.

Insert its power plug into an appropriate wall socket.

- i** Press the on/off switch only when you want to operate the appliance.
Pressing the on/off switch will give power to the appliance.
The appliance will start in accordance with the operation mode selected (see section 3.3.1) or possibly in accordance with the pre-set programmes (see section 3.3.7).
- i** Make sure the hopper is filled with enough pellets for the operating time that is set.

2.3.7 Plumbing connection

- !** **CAUTION:** Before making the water connections, it is advisable to flush the system; failure to take this precaution could in some cases cause deterioration of certain devices such as valves, pumps etc.
We strongly advise you to install a magnetic filter in the return in order to improve the life of the appliance; it also facilitates the removal of impurities and increases the overall system efficiency.

Connecting the appliance to the heating system must be implemented in consideration of the following technical features and functionalities:

- The appliance is equipped with a 6 liter expansion tank preset at the pressure of 1,5 bar, and having the expansion volume necessary for the quantity of water contained in the boiler. However, an additional expansion tank of appropriate capacity must be installed for the purposes of the water system.
- A high performance circulator (for the head and flow capacity characteristics see the following figures).
- The pressure of the system must never fall below 0,5 bar and must never exceed 2,5 bar.
- The normal expected operating pressure is 1,5 bar.
- The maximum system operating pressure is 2 bar.
- The safety valve installed in the appliance is calibrated at 3 bar. The valve release must be visible, environmental conditions permitting.

It is advisable to connect the appliance using flexible connections which will allow slight movement.
It is also advisable to fit interception gate valves on the water connections to allow the appliance to be moved if necessary.

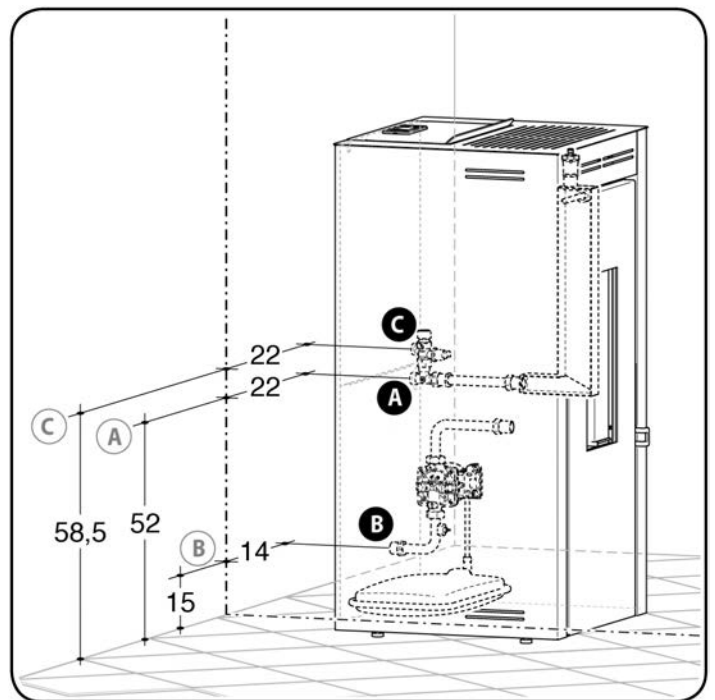

A. Delivery pipe to system (3/4" m)
B. Return pipe to system (3/4" m)
C. Heat release safety valve (1/2" f - 3 bar)

- i** The installer must fit a water drainage stopcock on the return pipe to system and a suitable non-return valve.
- i** For correct operation of the appliance, the return water temperature in operating conditions must be kept above 50°C; for this reason, in certain cases, it is necessary to fit an anticondensation diverter valve in the water system. Adhering to this temperature limit can prevent certain problems, such as the formation of condensation, creosote deposits on the walls, incomplete combustion, or the need for more frequent maintenance work.

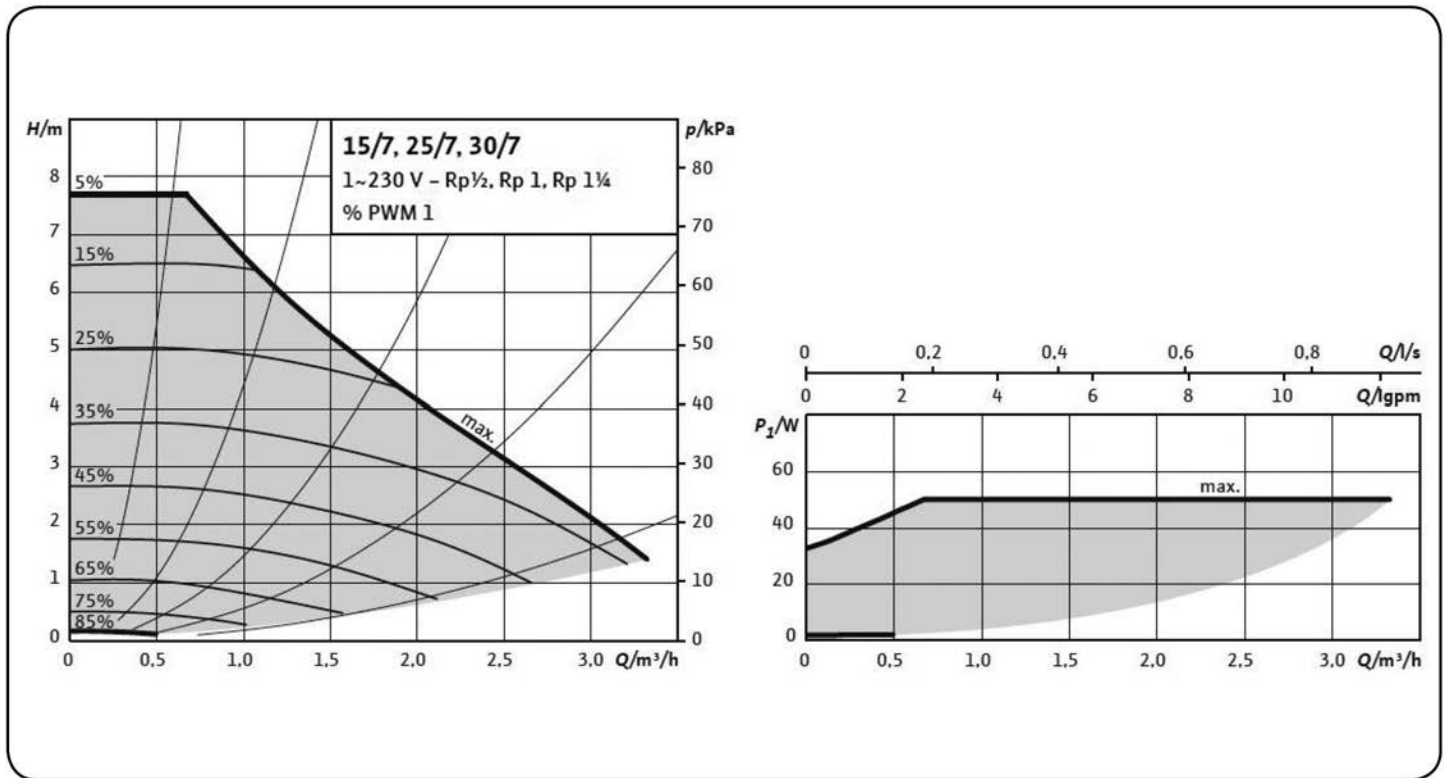

2.3.8 Filling the system

Before proceeding with filling the system, remember to bring the precharge pressure of the appliance's expansion tank and any other vessels present to a value of between 0.8 and 1.1 bar.



On the appliance there is an air vent device above the boiler, which must be kept open only for the duration of the filling and subsequent deaeration of the system; once these operations have been completed, it must be closed to prevent possible water leaks.

The plant must be equipped with a filling system compliant with the EN1717 standard. The boiler will be filled by means of a type C switch present in the system. It is advisable to fill the boiler slowly to allow the vent valve to eliminate the air from the boiler.



CAUTION: For correct operation it is advisable to charge the system cold at a pressure of between 0.8 and 1.1 bar; the pressure must be read on the appliance's display using the [STOVE STATUS] menu. It is also important that there should be no air at all in the system, and for this reason adequate devices should be fitted for bleeding the air.



Any operations for bleeding the air from the system or from the appliance do not come under the warranty.



We recommend periodically checking the pressure of the system and the precharge in the expansion tanks after a period in which the appliance has been out of use.



It is advisable to periodically check, when the appliance is off and cold, the absence of air in the boiler by opening the vent device located above the boiler. Once this operation has been completed, the vent device must be closed to avoid possible water leaks.



CAUTION: Do not add antifreeze or anticorrosion substances in the wrong concentrations: this could damage the system's seals.

2.3.9 Sample Installation Schematic

Below, for purely exemplary purposes, is an account of a type of system for room heating where the appliance is used as the sole source of heating.

As soon as it is lit, the fire immediately begins to supply heat to the water in the boiler.

When the water reaches the pre-set temperature limit, the temperature sensor sends a signal to the control unit, which automatically starts the circulation pump.

From this moment the hot water begins to flow through the entire water system and via a distribution manifold.

The heating system technician will be responsible for determining the most appropriate solution for all other user requirements.

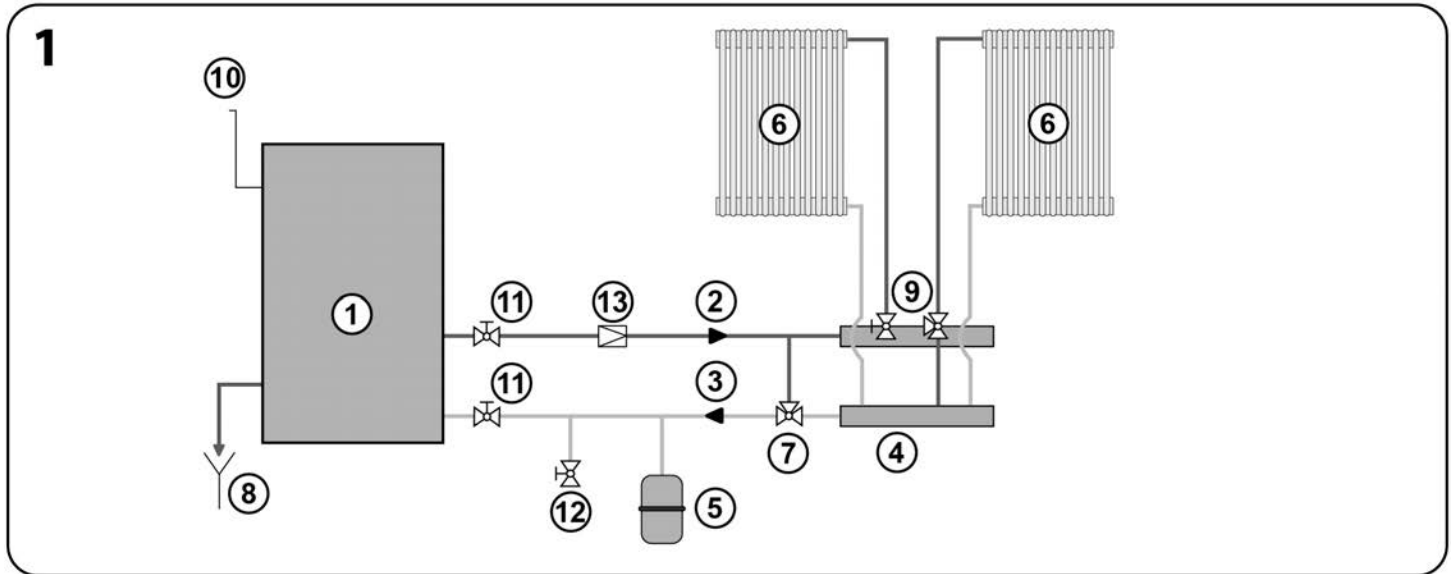

LEGEND FOR SCHEMATIC ABOVE

- | | | |
|---------------------------------|------------------------------------|------------------------------|
| 1. Appliance | 5. Expansion tank | 9. Zone valves |
| 2. Input feed line | 6. Radiator | 10. Ambient sensor |
| 3. Output feed line | 7. Anticondensation diverter valve | 11. Interception gate valves |
| 4. Water distribution collector | 8. Release safety valve | 12. Drainage stopcock |
| | | 13. Non-return valve |

3 OPERATION

3.1 Pre- and first-lighting instructions

Before lighting the appliance for the first time the following must be done:

- Remove the sticker from the glass and any adhesive marks if necessary.
- Ensure that all safety requirements are met (see sections 1.5 and 1.6).
- Electrical connection: After verifying that the line voltage is correct (230 V~ 50 Hz), flip the main switch located on the back panel of the appliance to the "ON" position.
- Check that the control panel display lights up, which indicates that appliance is powered.
- make sure the hopper is filled with enough fuel for the desired service time.

i The fuel quality standards must comply with what prescribed under section 1.4.

! CAUTION: Children must be supervised by an adult in order to prevent them from touching the appliance hot parts or modifying its functions.

i The metal component parts of the appliance are coated with a special high temperature paint that will reticulate, chemically stabilize and become fully heat resistant after the first few lightings. During this chemical reaction, the paint will smell bad and release vapours, thus it is recommended that the room be properly aerated. When this process is finished, no more bad smell and vapours will be released during the appliance normal operation.

3.2 Pellet loading

Open the lid of the loading port and fill the hopper with pellets of $6 \pm 1,0$ mm \varnothing with length $3,15 \leq L \leq 40,0$ mm (EN 17225-2 – Category A1).

! **WARNING:** While the appliance is working, the lid of the pellet hopper can only be left open for 30 seconds at the most; if it is left open for longer than this time, the safety device trips with related acoustic alarm signal, which activates the appliance shutdown procedure (see section 3.3.8).

! **CAUTION:** Do not remove the protection grate that is mounted inside the hopper.

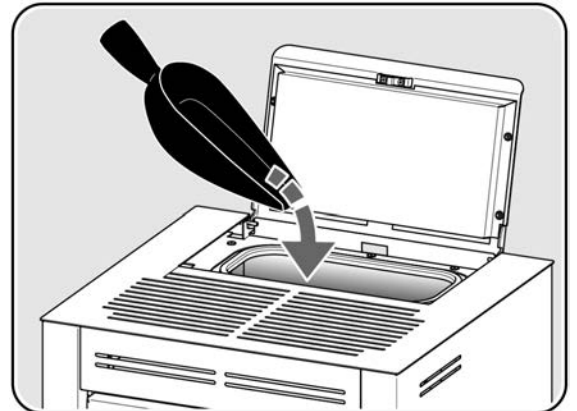

! **ATTENTION:** The pellet that should accidentally fall outside the reservoir while loading it could come into contact with very hot parts of the appliance with the resulting risk of a fire. It is therefore necessary to use a specific shovel so that the pellet bag does not burden on the reservoir and/or does not touch the hot parts of the appliance. The pellet that should fall out of the reservoir and finish in the areas between the reservoir and the cladding must be immediately removed.

! **IMPORTANT:** To ensure correct functioning of the appliance always close the lid of the hopper after refilling.

i Check the quantity of pellets in the hopper from time to time, and refill promptly whenever necessary in order to avoid setting off an appliance alarm due to low fuel level (the sustained sound of the acoustic alarm may cause a nuisance until the user has a chance to reset the system).







3.3 Control panel



CONTROL PANEL

Control unit buttons

The control panel of the appliance is equipped with a lit display and with six buttons as described below:

-  [P1] = [SET WATER TEMPERATURE] on the left side of the control panel.
-  [P2] = [SET AMBIENT TEMPERATURE] on the left side of the control panel.
-  [P3] = [MENU SET] on the left side of the control panel.
-  [P6] = [SET POWER] on the right side of the control panel.
-  [P5] = [SET FAN] on the right side of the control panel.
-  [P4] = [ON/OFF] on the right side of the control panel.

Activation indicators

The appliance's control panel also has seven icons on the left side of the display, as illustrated below. During operation of the appliance, the corresponding activation indicators adjacent to these icons will light up.

-  thermostat activation icon.
-  ignition resistance icon.
-  screw auger icon.
-  smoke exhauster icon.
-  fan icon.
-  circulation pump icon.
-  alarms icon.

3.3.1 Ignition

i Before switching on the appliance check the correct positioning of the internal movable parts of the combustion chamber.

Before operating your appliance again, clean the ceramic glass door if needed (see section 4.1.2), remove any residual combustion products from the burn pot, clean the firebox, and vacuum up the ash residues in the burn pot and ash pan (see section 4.1.3). If the appliance has not been used for a long time, remove any pellets that may still be in the fuel hopper because they could have lost their original properties which ensure a good combustion. Also vacuum any pellet sawdust from the hopper.

! **IMPORTANT: This last procedure must be carried out using an appropriate vacuum cleaner. Never remove the protective grate from the top of the pellet hopper for any reason, not even temporarily.**

Activate the appliance, setting the switch on the rear to "1". Activation is confirmed by the control panel switching on, which goes to the main screen ([OFF] appears on the display).

The following can be viewed on the display: the time on the top line, the ambient temperature, set operating power and water temperature one after the other on the middle line, and the appliance's state of operation on the bottom line.

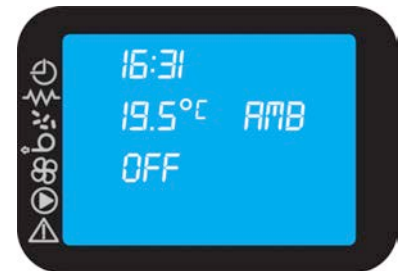

i In the event of the first start-up or after an alarm due to pellets running out: remember that the fuel feed screw auger is empty, therefore adequate time is needed for it to fill and to fuel the burner. To do this, use the [LOAD INITIAL] function on the menu.

To switch the appliance on, long press the button [P4]. Switching on is indicated on the display with the word [START].

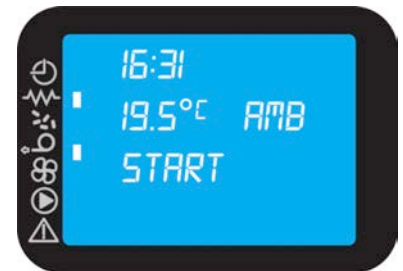

Any faults during the light up phase are indicated on the display and the appliance will go into alarm condition (see section 3.3.8). Once ignition has started, the following operating conditions occur: [AWAITING PREHEATING], [LOADING PELLETS], [AWAITING FLAME] and [FIRE].

After the appliance has reached adequate fuel development and sufficient heating is maintained for a suitable time, it enters the the work condition which is the normal operating condition. The display indicates the [WORK] condition.

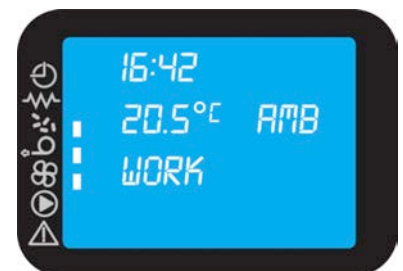

At intervals adjusted by the electronic board, the appliance goes into "cleaning" operating mode in order to keep the burner clean and efficient, indicating [CLEANING FIRE-POT] on the display.



! **IMPORTANT:** If ignition fails, the appliance goes into the "ignition failed" alarm condition and the display will show the message [NO LIGHTING].
Before carrying out a second ignition attempt, completely empty the burner of the fuel that accumulated during the first attempt.

! **WARNING** In the following cases always remove any pellets that may still be in the burn pot before restarting the appliance:

- After every failed ignition.
- After selecting the switching off mode before the ignition cycle is completed.
- On re-ignition after switching off for lack of fuel.

! **ATTENTION:** For safety reasons never put these pellets in the fuel hopper.

3.3.2 Extinguishing

To switch off the appliance, simply long press the button [P4]. The message [FINAL CLEANING] will appear on the display.

The screw auger will stop.

The air exchange fan and the smoke exhauster will remain on until the appliance has completely cooled down. After a preset period, if the appliance stays cold, it switches off and the message [OFF] appears on the display.

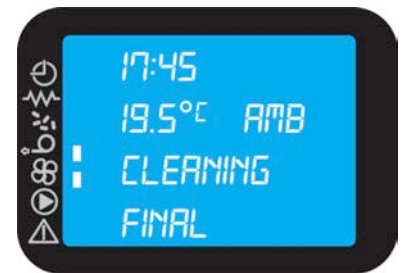

! **CAUTION:** Never switch off the appliance by disconnecting the power plug.
This may adversely affect the structural integrity of the appliance and cause failures by the following lighting.

3.3.3 Maximum operating power set adjustment

The appliance has 5 operating power settings and they are automatically managed by the appliance. From the main screen, you can change the maximum operating power by pressing the buttons [P5] and [P6].

The value can then be modified by pressing buttons [P2] and [P1].

The set power is indicated on the display.

To exit the set menu, wait 5 seconds without carrying out any operations on the control panel or press [P4]. The modifiable sets power go from 1 to 5.



! **CAUTION:** Never switch off the appliance by disconnecting the power plug.
This may adversely affect the structural integrity of the appliance and cause failures by the following lighting.

3.3.4 Ambient temperature set adjustment

From the main screen, you can change the set ambient temperature by simply pressing the button [P2].

The display indicates the set ambient temperature [SET TEMP ROOM]

Therefore, by pressing the buttons [P2] (decrease) and [P1] (increase), you can change the value. After about 5 seconds, the value is stored and the display returns to the main screen, or to exit, press the button [P4].



When the ambient temperature has reached the set value, the appliance power will automatically switch to the minimum value. In these conditions, the display indicates the message [WORK MODULAT-].

If the ambient temperature drops below the set temperature, the appliance resumes at the previously set power.



H2O MODE:

If the ambient temperature is set above 40°C, the display will indicate [H2O] and the appliance will switch to H2O mode, taking as its reference only the set water temperature and no longer also the ambient temperature.

THERMOSTAT MODE:

If the ambient temperature is set below 6°C, the display will indicate [therm] and the appliance will switch to thermostat mode. This mode allows the appliance to ignite or switch off using a thermostat or an external switch connected to the specific terminal block on the back of the appliance (see section 5.2).

After activating thermostat mode, you can check the ignition request from the external thermostat by viewing the specific activation indicator on the upper left of the display.

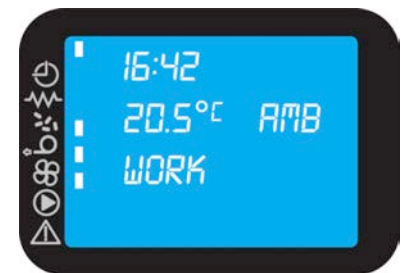

STAND BY:

If the stand-by function is activated from the appropriate menu (see para. 3.3.7), it switches off the appliance if, for a preset time, the ambient temperature is 3°C above the set temperature, the water temperature is 5°C above the set temperature, or if the thermostat contact or the external switch contact is open. The display will indicate [AWAITING COOLING].

Once cooling is completed, the appliance switches on again when the ambient temperature drops to 1°C below the set temperature.



CAUTION: Never switch off the appliance by disconnecting the power plug. This may adversely affect the structural integrity of the appliance and cause failures by the following lighting.

3.3.5 Set water temperature

From the main screen you can change the set water temperature by simply pressing the button [P1].

The display shows the set water temperature [WATER SET TEMP].

The value can be changed by pressing the buttons [P5] and [P6]. After about 5 seconds, the value is stored and the display returns to the main screen, or to exit, press the button [P4].



3.3.6 Set fan

From the main screen you can set the ambient air fan speed by simply pressing the button [P5].

The display shows the set speed [FAN SETTING].

The value can be changed by pressing the buttons [P5] and [P6]. After about 5 seconds, the value is stored and the display returns to the main screen, or to exit, press the button [P4].

By setting the fan value at "0" the fan will remain switched off. By setting it at "5" it will operate at maximum speed, and if set at "A" it will operate proportionally in relation to the 5 operating powers.



IMPORTANT: The fan will operate only if the water temperature is hot enough to guarantee a minimum hot air flow.

3.3.7 Menu

To access the menu, press the button [P3]. The display will indicate [MENU 01 AIR VENT].

The menu is subdivided into various items and submenu levels that permit access to the appliance's settings and programming.

To scroll through the menus and submenus, press the buttons [P5] or [P6].

To confirm the desired menu selection, press the button [P3] and then press [P1] or [P2] to change the values.

To exit and return to the previous screen, press the button [P4].

Menu 01 - (AIR VENT):

This function, available only when the appliance is in [OFF] condition, allows the circulation pump to switch on and off in order to release the air in the boiler.

After selecting the menu, press the button [P1] to activate the air vent.

To exit and return to the previous screen, press the button [P4].



Menu 02 - SET CLOCK:

Confirm the menu choice with button [P3].

Set the current date and time To enter the menu, press the button [P3]. Select the desired day of the week by pressing [P1] or [P2] and confirm by pressing button [P3]. This is followed by setting of the hour, minutes, day of the month, the month and the year by pressing the buttons [P1] or [P2] and confirm by pressing button [P4].

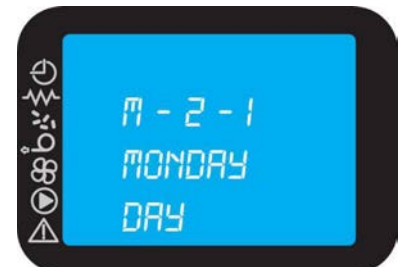

Menu 03 - SET PROGRAMMABLE THERMOSTAT:

Confirm the menu choice with button [P3].

These menus permit you to set all the programmable thermostat functions. To enter the menu, press the button [P3] and then press [P5] or [P6] to select the desired submenu. Confirm with the button [P3].

To exit and return to the previous screen, press the button [P4].

**Submenu 3 - 1 ENABLE PROGRAMMABLE THERMOSTAT:**

Confirm the menu choice with button [P3].

This allows you to enable and disable the programmable thermostat. Press [P1] to enable "on", [P2] to disable "off" and confirm with the button [P4]. Enabling the programmable thermostat is confirmed by a programmable thermostat icon that turns on if at least one of the three programmes described below is activated (daily, weekly or weekend programme).

**Submenu 3 - 2 SET DAY:**

Confirm the menu choice with button [P3].

This allows you to enable and edit the programmable thermostat's daily programme. Press [P1] to enable "on" or [P2] to disable "off". To confirm and move to the next screen, press the button [P5] and to exit press the button [P4].



The appliance has 2 daily programs that allow it to be switched on twice and switched off twice per day.

- **Start 1 day**

To set the first ignition time (start 1) for the appliance, press [P1] or [P2]. To ignore the first ignition, set the time to "OFF", confirm and move on to the next screen with the button [P5].

- **Stop 1 day**

To set the first extinguishing time (stop 1) for the appliance, press [P1] or [P2]. To ignore the first extinguishing, set the time to "OFF", confirm and move on to the next screen with the button [P5].

- **Start 2 day**

To set the second ignition time (start 2) for the appliance, press [P1] or [P2]. To ignore the second ignition, set the time to "OFF", confirm and move on to the next screen with the button [P5].

- **Stop 2 day**

To set the second extinguishing time (stop 2) for the appliance, press [P1] or [P2]. To ignore the second extinguishing, set the time to "OFF", confirm and move on to the next screen with the button [P5].

Enabling the daily programme is confirmed by the specific activation indicator that turns on at the top of the display.

Ignition of the appliance through the daily programme takes place only if the programmable thermostat is enabled at the same time from submenu 3 – 1 – 1.

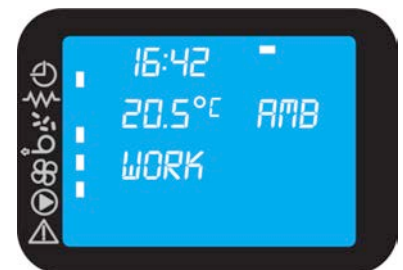

Submenu 3 - 3 WEEKLY PROGRAMME:

Confirm the menu choice with button [P3].

This allows you to enable and edit the programmable thermostat's weekly programme. Press [P1] to enable "on" or [P2] to disable "off". To confirm and move to the next screen, press the button [P5].



The appliance has 4 weekly programs that allow it to be switched on 4 times and switched off 4 times per day. Each program offers 9 options in rotation for setting/enabling, according to the following table.

| program 1 | program 2 | program 3 | program 4 |
|----------------------------|----------------------------|----------------------------|----------------------------|
| Start prog 1 | Start prog 2 | Start prog 3 | Start prog 4 |
| Stop prog 1 | Stop prog 2 | Stop prog 3 | Stop prog 4 |
| Monday prog 1 | Monday prog 2 | Monday prog 3 | Monday prog 4 |
| Tuesday prog 1 | Tuesday prog 2 | Tuesday prog 3 | Tuesday prog 4 |
| Wednesday prog 1 | Wednesday prog 2 | Wednesday prog 3 | Wednesday prog 4 |
| Thursday prog 1 | Thursday prog 2 | Thursday prog 3 | Thursday prog 4 |
| Friday prog 1 | Friday prog 2 | Friday prog 3 | Friday prog 4 |
| Saturday prog 1 | Saturday prog 2 | Saturday prog 3 | Saturday prog 4 |
| Sunday prog 1 | Sunday prog 2 | Sunday prog 3 | Sunday prog 4 |
| <i>continues program 2</i> | <i>continues program 3</i> | <i>continues program 4</i> | <i>continues program 1</i> |

- **Start program 1/2/3/4**

To set the first/second/third/fourth ignition time (start prog 1/2/3/4) for the appliance, press [P1] or [P2]. To ignore the first/second/third/fourth ignition, set the time to "OFF", confirm and move on to the next screen with the button [P5].

- **Stop program 1/2/3/4**

To set the first/second/third/fourth extinguishing time (stop 1/2/3/4) for the appliance, press [P1] or [P2]. To ignore the first/second/third/fourth extinguishing, set the time to "OFF", confirm and move on to the next screen with the button [P5].

- **Monday prog 1/2/3/4**

To enable this programme on Monday, press [P1] "ON". To disable it, press [P2] "OFF". Confirm and move to the next screen with the button [P5].

- **Tuesday prog 1/2/3/4**

To enable this programme on Tuesday, press [P1] "ON". To disable it, press [P2] "OFF". Confirm and move to the next screen with the button [P5].

- **Wednesday prog 1/2/3/4**

To enable this programme on Wednesday, press [P1] "ON". To disable it, press [P2] "OFF". Confirm and move to the next screen with the button [P5].

- **Thursday prog 1/2/3/4**

To enable this programme on Thursday, press [P1] "ON". To disable it, press [P2] "OFF". Confirm and move to the next screen with the button [P5].

- **Friday prog 1/2/3/4**

To enable this programme on Friday, press [P1] "ON". To disable it, press [P2] "OFF". Confirm and move to the next screen with the button [P5].

- **Saturday prog 1/2/3/4**

To enable this programme on Saturday, press [P1] "ON". To disable it, press [P2] "OFF". Confirm and move to the next screen with the button [P5].

- **Sunday prog 1/2/3/4**

To enable this programme on Sunday, press [P1] "ON". To disable it, press [P2] "OFF". Confirm and move to the next screen with the button [P5].

Enabling the weekly programme is confirmed by the specific activation indicator that turns on at the top of the display.

Ignition of the appliance through the weekly programme takes place only if the programmable thermostat is enabled at the same time from submenu 3 – 1 – 1.



Submenu 3 - 4 WEEKEND PROGRAMME:

Confirm the menu choice with button [P3].

This allows you to enable and edit the programmable thermostat's weekend (Saturday and Sunday) programme. Press [P1] to enable "on" or [P2] to disable "off". To confirm and move to the next screen, press the button [P5].

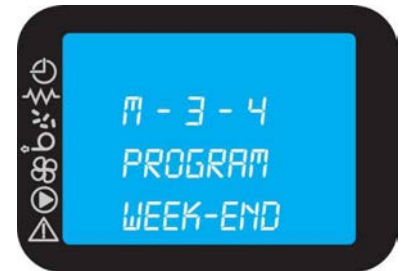

The appliance has 2 weekend programs that allow it to be switched on twice and switched off twice per day. The maximum operating power and the ambient temperature can also be set for each programmed time-band.

- **Start 1 WEEK - END**

To set the first ignition time (start 1) for the appliance, press [P1] or [P2]. To ignore the first ignition, set the time to "OFF", confirm and move on to the next screen with the button [P5].

- **Stop 1 WEEK - END**

To set the first extinguishing time (stop 1) for the appliance, press [P1] or [P2]. To ignore the first extinguishing, set the time to "OFF", confirm and move on to the next screen with the button [P5].

- **Start 2 WEEK - END**

To set the second ignition time (start 2) for the appliance, press [P1] or [P2]. To ignore the second ignition, set the time to "OFF", confirm and move on to the next screen with the button [P5].

- **Stop 2 WEEK - END**

To set the second extinguishing time (stop 2) for the appliance, press [P1] or [P2]. To ignore the second extinguishing, set the time to "OFF", confirm and move on to the next screen with the button [P5].

Enabling the weekend programme is confirmed by the specific activation indicator that turns on at the top of the display.

Ignition of the appliance through the weekend programme takes place only if the programmable thermostat is enabled at the same time from submenu 3 – 1 – 1.

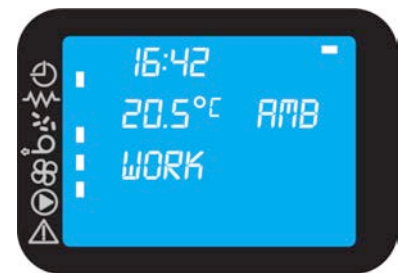

Menu 04 - SELECT LANGUAGE:

Confirm the menu choice with button [P3].

This allows you to choose the language from those available. Scroll through the languages using the buttons [P1] or [P2], confirm and return to the previous screen using the button [P4].

**Menu 05 - STANDBY MODE:**

Confirm the menu choice with button [P3].

This allows you to disable the standby function. To enable or disable, press the buttons [P1] or [P2]. To confirm and return to the previous screen, press the button [P4].

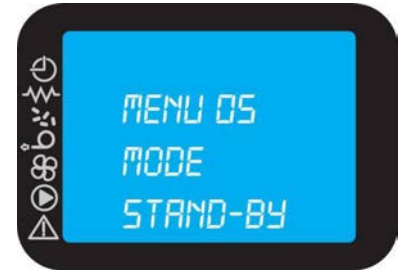
**Menu 06 - BUZZER MODE:**

Confirm the menu choice with button [P3].

This allows the acoustic signal buzzer to be enabled or disabled during alarm conditions. To enable or disable, press the buttons [P1] or [P2]. To exit and return to the previous screen, press the button [P4].

**Menu 07 - INITIAL LOADING:**

Confirm the menu choice with button [P3].

This function, available only when the appliance is in [OFF] condition, allows the screw auger to be loaded at the first start-up when the fuel reservoir is empty or after a no-pellets alarm event.

After selecting menu 07, press the button [P1]. The screw auger activates and remains in operation until the time indicated on the display runs out or until the button [P4] is pressed.

**Menu 08 - STOVE STATUS:**

This function is only for installers or expert personnel and it allows the status of a few variables to be viewed during operation of the appliance.



Menu 09 - PELLET TYPE:

Confirm the menu choice with button [P3].

This function provides the facility to view and edit the combustion parameters associated with the pellet load.

! ATTENTION: Loading the pellet through the feeding system on the appliance is influenced by the characteristics of the pellet itself. Introducing different supplies of pellets you can find loading differences that can reach 20/25%, which translate into variations in thermal power introduced (see paragraph 1.4).



At the first ignition check for at least 6 continuous hours that the combustion meets the following requirements:

- there must not be any tendency to fuel build up in the burn pot given to an excess of fuel or lack of draught.
- There must not be any tendency to flame extinguishing for lack of fuel or for excessive draught.

Since the proper functioning of the appliance depends on the environmental conditions and especially on the draught, on the connection to the chimney flue and on the type of pellet used, should the user notice one of the above tendencies, after having checked that the stove is perfectly cleaned (see paragraphs 4.1.3, 4.2.1 and eventually 4.2.2), a different set of parameters among those available and set by the factory could be necessary.

There are 19 parameters organised according to the pellet density and specific gravity.

Choose the most appropriate parameter to guarantee good combustion, according to the following indications:

- If the pellets tend to build up in the burn pot, choose a parameter lower than the current one, monitor combustion for at least one hour, and, if necessary, reduce the parameter setting until the combustion requirements illustrated above are met.
- If there is a tendency for the flame to extinguish, choose a higher parameter than the current one, monitor combustion for at least one hour, and, if necessary, increase the parameter setting until the combustion requirements illustrated above are met.

Use buttons [P1] and [P2] to adjust the pellet load percentage from a maximum value of + 9 to a minimum of - 9. Each change alters the pellet load of all 5 power settings of the unit. (Parameter factory setting = 0).

! ATTENTION: It is recommended to carry out the combustion calibration correctly because in case of flame extinguishment, unburnt pellet could distillate in the burn pot and lead to its explosion in the combustion chamber.

Summary parameter table

Parameters to be selected when there is a tendency to
FLAME EXTINGUISHING

| | | | | | | | | | | | | | | | | | | |
|----|----|----|----|----|----|----|----|----|---|---|---|---|---|---|---|---|---|---|
| -9 | -8 | -7 | -6 | -5 | -4 | -3 | -2 | -1 | 0 | 1 | 2 | 3 | 4 | 5 | 6 | 7 | 8 | 9 |
|----|----|----|----|----|----|----|----|----|---|---|---|---|---|---|---|---|---|---|

Parameters to be selected when there is a tendency to
PELLET BUILD UP

Menu 10 - TECHNICAL CALIBRATION:

CAUTION: Access to this menu, allowed by inserting an access key, is for installers or expert personnel, since the parameters shown, if modified, may render the product unsuitable for application in use.

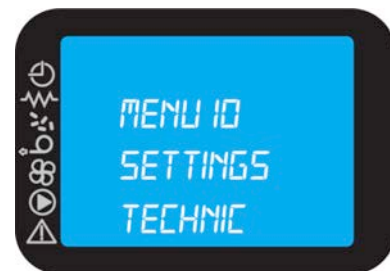

3.3.8 Alarm signals

 **CAUTION: Always remove any pellets that may still be in the burn pot before restarting the appliance, when an alarm causes the turning off of the appliance.**

If an operational fault should occur, the appliance intervenes and signals the anomaly, switching on the alarms indicator icon on the display and emitting acoustic signals.

 **Any alarm situation causes the appliance to switch off immediately.**

The alarm condition is reached after a time of 30 seconds except for the BLACK OUT alarm and it can be reset by long pressing the button [P4]. Each time an alarm is reset, the appliance initiates a shut-down phase for safety reasons. In the alarm phase, an alarm icon is always active on the display and, if enabled, the buzzer sounds intermittently. If the alarm is not reset, the appliance initiates shut-down anyway, leaving the alarm message on the display.

 **IMPORTANT: After each alarm event, you must always wait for the appliance to cool down completely, after which you may proceed with disconnecting it, setting the switch on the rear to "0" and, if maintenance is required, disconnecting the electrical plug. After carrying out the indications for the respective solutions, you may proceed with start-up, setting the switch on the back to "1" and after having waited for the appliance to return to the [OFF] condition.**

An alarm situation can be caused by a breakdown on the appliance; in this case, if the appliance does not start up correctly after the respective instructions for the solutions have been carried out, the services of a qualified technician are necessary to reactivate the appliance and to check the causes that triggered the alarm.

BLACKOUT ALARM:

While the appliance is working, there may be an electric power failure. On restarting, if the power failure period is less than 30 seconds, the appliance starts up again in WORK mode; otherwise the alarm intervenes.

On the display the relative message appears and the appliance goes into alarm condition, initiating shut-down.

SMOKE SENSOR ALARM:

This occurs if the smoke sensor is faulty.

On the display the relative message appears and the appliance goes into alarm condition, initiating shut-down.

*Solution: The services of a qualified technician will be required to first verify what set off the alarm, and then to correct the problem.

BLACK HOT EXHAUST ALARM (smoke overtemperature):

Indicates that the smoke temperature is too high because of:

- Lack of ordinary cleaning maintenance of the appliance.
- Incorrect combustion calibration.

On the display the relative message appears and the appliance goes into alarm condition, initiating shut-down.

Solution: In the first case, routine maintenance must be carried out, and in the second case, the services of a qualified technician are necessary to modify the combustion parameters.

FAN FAILURE ALARM (smoke extractor faulty):

This appears if there is a fault on the smoke exhauster.

On the display the relative message appears and the appliance goes into alarm condition, initiating shut-down.

*Solution: The services of a qualified technician will be required to first verify what set off the alarm, and then to correct the problem.

NO LIGHTIN- ALARM- (failed ignition):

This occurs when the ignition phase fails.

On the display the relative message appears and the appliance goes into alarm condition, initiating shut-down.

Solution: Check the cleaning of the burn pot and the part underneath (see section 4.1.3).

All the fuel present in the burn pot must always be removed.

NO-PELLET ALARM:

The fuel in the reservoir is depleted.

Solution: with the appliance switched off and cold, all the fuel present in the burn pot must always be removed.

IMPORTANT: Before restarting the appliance, the fuel reservoir must be refilled and the [INITIAL LOAD] function must be activated from the menu.

IMPORTANT: If the fuel shows a tendency to extinguish, correct and increase the calibration parameter, using Menu 09 - PELLET TYPE.

THERMAL SAFETY ALARM:

This occurs when the safety thermostat detects a water temperature higher than the trigger threshold. The thermostat intervenes and switches off the screw auger, as it is placed in series with its power supply, and the appliance signals the alarm status.

On the display the relative message appears and the appliance goes into alarm condition, initiating shut-down.

Solution: Once the switch-off phase is terminated, the following operations are necessary:

- Set the switch located on the rear of the appliance to "0".
- Reset the thermostat located on the back of the appliance on the right (by unscrewing the black hood that covers it, pressing the button at the centre and screwing back the hood).



IMPORTANT: check that the air in the appliance is completely released by means of the appropriate venting devices and also check that there are no obstructions that might prevent or limit the water circulation as these may have caused an increase in the temperature.

PRESSURE LOSS ALARM:

This occurs when the depressimeter detects that the combustion chamber door or the reservoir top are open, or if it detects that the exchanger cover is not closed correctly or that there is an overpressure in the smoke exhauster flue. The depressimeter intervenes and switches off the screw auger, as they are electrically connected in series, and the appliance signals the alarm status.

On the display the relative message appears and the appliance goes into alarm condition, initiating shut-down.

Solution: If the fault is temporary, the appliance returns to normal operation when it is eliminated; if, however, it persists, check that the smoke evacuation duct is free from obstructions and that the openings mentioned above are correctly closed.

WATER SENSOR ALARM:

Indicates faults or malfunctions in the sensor that detects the water temperature.

*Solution: The services of a qualified technician will be required to first verify what set off the alarm, and then to correct the problem.

HOT WATER ALARM:

Indicates that the temperature of the flow water has exceeded the safety limit.

*Solution: check for feasible anomalies in the hydraulic system, which could be preventing the water from circulating. Also make sure the H2O temperature is not set too high.

WATER PRESSURE ALARM:

Indicates that the pressure is under or over the set limit, as indicated by the pressure transducer.

*Solution: Check the pressure of the system and rectify accordingly so that it rises above 0.5 bar or drops below 2.5 bar.

The appliance is equipped with a 6 liter expansion tank preset at the pressure of 1,5 bar, and having the expansion volume necessary for the quantity of water contained in the boiler. However, an additional expansion tank of appropriate capacity must be installed for the purposes of the water system.

AIR SENSOR ALARM:

Indicates overheating in the pellet hopper. that the room temperature sensor is broken or damaged.

*Solution: The services of a qualified technician will be required to first verify what set off the alarm, and then to correct the problem.

3.3.9 SERVICE signal

To ensure constant and efficient operation of the appliance, you must carry out the routine maintenance work stated, which varies according to the hours of operation and the quantity of fuel burnt. When the appliance reaches 2000 hours of operation, the message SERVICE appears on the control panel, meaning that it has to be serviced by a qualified technician.

4 CARE AND MAINTENANCE

4.1 Recurrent maintenance

Do not forget that performing the following recurrent maintenance will ensure your appliance efficiency and proper operation for a long time.



WARNING: All cleaning of the various parts must be done when the appliance is completely cold and disconnected from the electrical power source (electrical plug disconnected).

Cleaning and maintenance operations to be carried out by the user cannot be done by unattended children.

4.1.1 Cleaning of display screen and exterior cladding elements

Clean with a dry, soft cloth; do not use any detergent or cleaning products.

4.1.2 Cleaning of ceramic glass

To perform if needed.



The quality and type of fuel as well as the way of use can determine the frequency of cleaning the ceramic glass.

1. We recommend the use of a specific glass cleaner for perfect cleaning;
2. spray some cleaner on a soft cloth to remove any tar and soot stains from the glass.



Never spray the ceramic glass directly with a specific glass cleaner or with any other cleaning product



The use of any abrasive sponges or similar for cleaning the ceramic glass panel is **FORBIDDEN**; failure to do so may result in permanent damage.



IMPORTANT: Ensure that you lock the door correctly with the equipped tool after opening it sideways to perform the ceramic glass cleaning.



4.1.3 Recurrent maintenance of type A

To perform at least twice a week or daily, depending on the operational conditions.

i By operating your appliance over a period of time you will find out how frequently it needs to be inspected and cleaned.

! **WARNING:** All cleaning of the various parts must be done when the appliance is completely cold and disconnected from the electrical power source (electrical plug disconnected).

The frequency of maintenance performed on your appliance is directly proportional to the operation hours and the performance requested.

! **CAUTION:** For safety reasons, before cleaning the appliance make sure the ashes have cooled completely and then remove them with a vacuum cleaner.

The recurrent maintenance works of type A are as follows:

1. Open the door of the firebox slowly, so as not to scatter/rise the ashes accumulated.
2. Remove the burn pot [B].
- 3a. From burn pot [B], remove any ashes and ash material that may accumulate and clog the air admission openings by means of a vacuum cleaner and a wire brush or any other tool sufficiently abrasive.
- 3b.
4. Lift the firebox ash collecting drawer [H] and take it completely out to empty it.

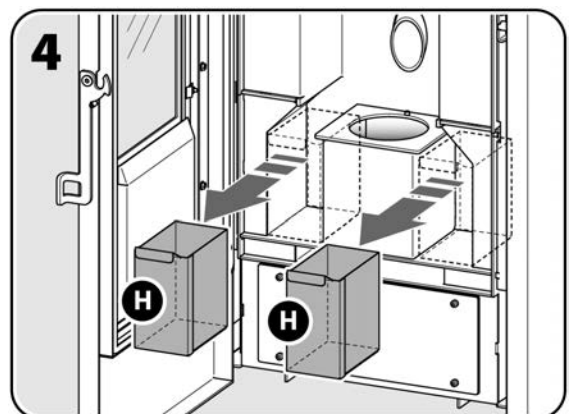
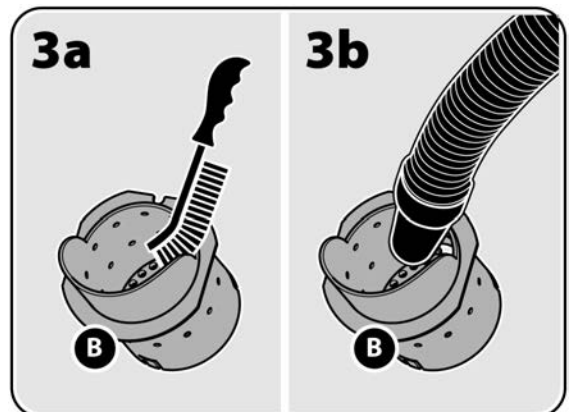
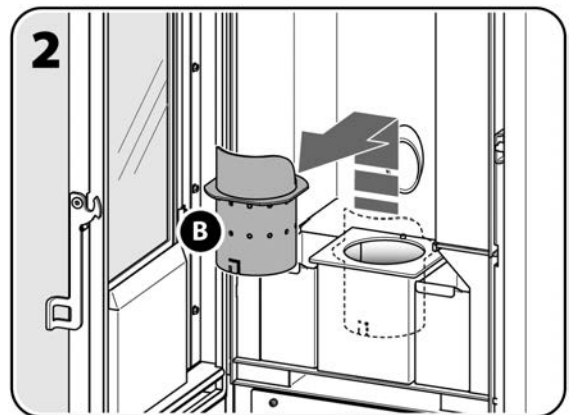
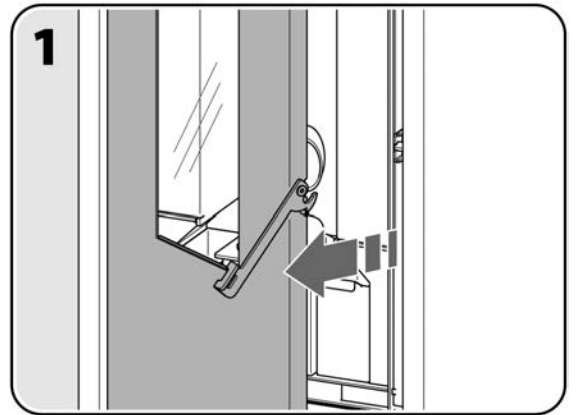

5. Remove any ashes that may accumulate inside the firebox, the burn pot
6. ash-tray and the door by means of a powerful vacuum cleaner (1000÷1300 W).

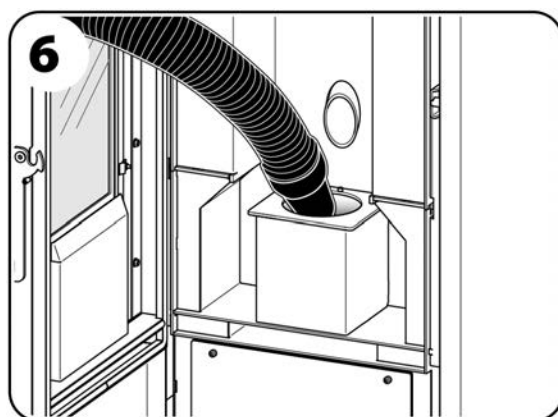
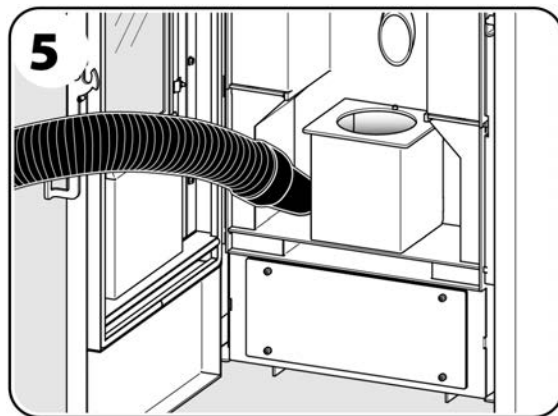

7. Vacuum clean all the ashes collected on the door.

When the cleaning is completed, install all the parts removed following the inverted order.

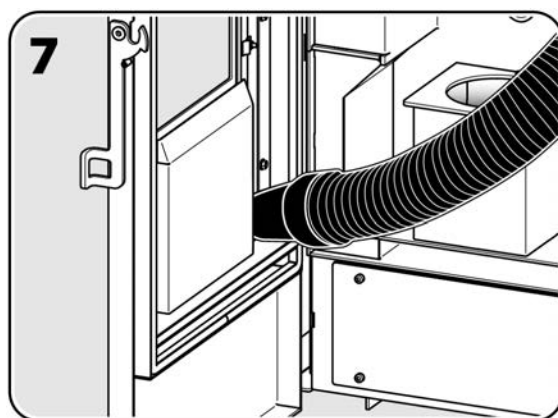

4.2 Routine maintenance

Do not forget that performing the following routine maintenance (type B and C) will ensure your appliance efficiency and proper operation for a long time. The same care and maintenance should be provided to the smoke exhaust system so as not to invalidate the work done on the appliance.

! **IMPORTANT:** after approximately 150 h of use or after 200 kg of fuel consumed, it is important to check and clean the smoke exhaust through the corresponding inspection doors or, if they are not present, dismantle the removable components.

4.2.1 Routine maintenance of type B

To perform in addition to recurrent maintenance of type A every 350÷400 hours or 500÷600 kg of pellets.

! **WARNING:** All cleaning of the various parts must be done when the appliance is completely cold and disconnected from the electrical power source (electrical plug disconnected).

! **CAUTION:** For safety reasons, before cleaning the appliance make sure the ashes have cooled completely and then remove them with a vacuum cleaner.

! **ATTENTION:** To be on the safe side, wear work gloves.

This operation must be carried out by partially removing the outer casing. The routine maintenance works of type B are as follows:

1. Clean the back panel of the combustion chamber [S] with the 90° flue brush (included).
2. Using a vacuum cleaner, remove all the soot and ashes from the combustion chamber [S].
3. Open the cover of the fuel tank and remove the top element of the cladding.

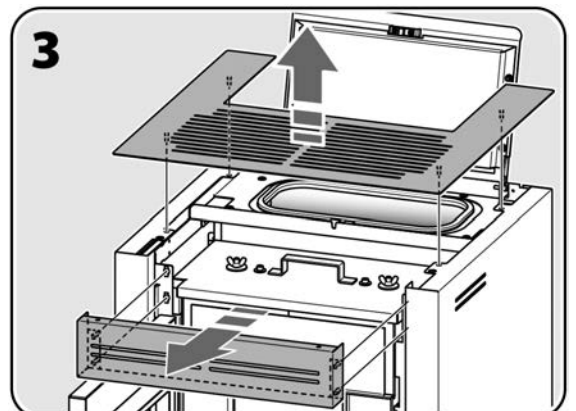
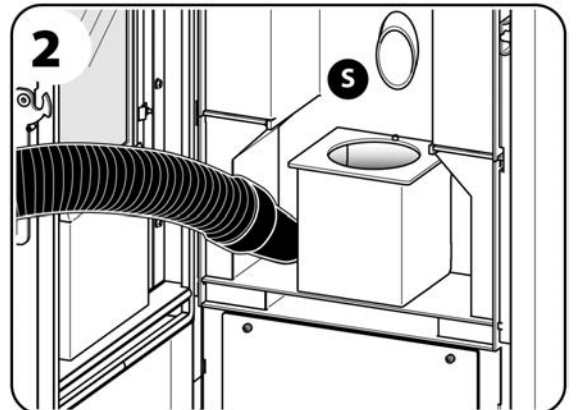
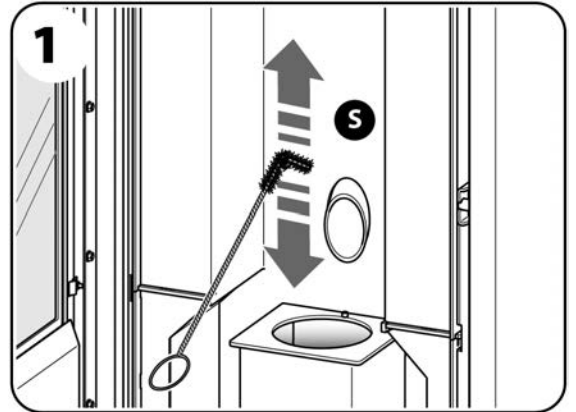

4. Unscrew and remove the two winged screws that secure the internal cover [F].

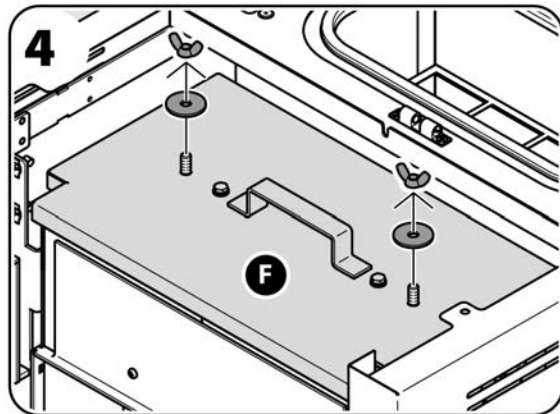

5. Remove the internal cover [F].

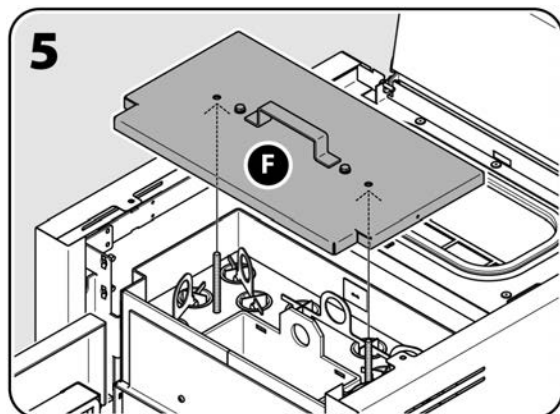

6. Carefully vacuum away any soot and ashes that have accumulated inside.

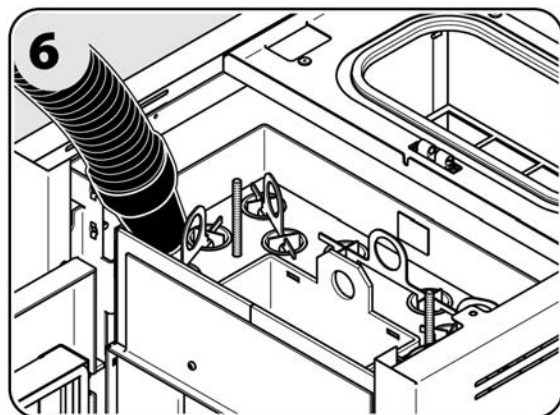

7. Lift the 10 turbulators out and vacuum the soot off them.

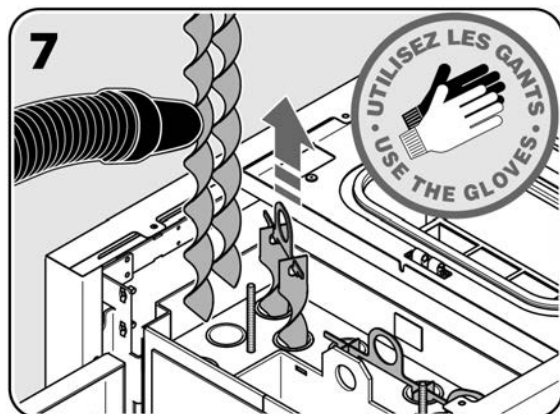

- 8a. Unscrew and remove the 4 screws holding the cover of the heat exchanger dust collecting compartment [V].

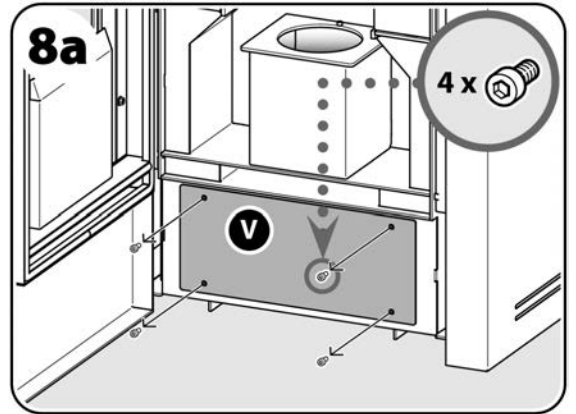

- 8b. Remove the heat exchanger dust collecting compartment lid [V] taking care to maintain the seal.

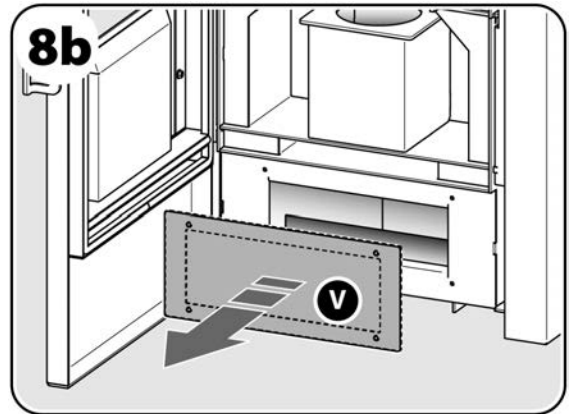

- 9a. To remove the soot, remove both the metal plates located inside the heat exchanger dust collector compartment and vacuum up all the ash and soot remaining in the compartment.

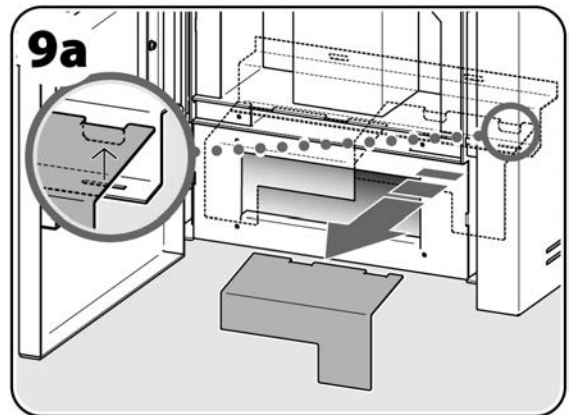

When the cleaning is completed, install all the parts removed following the inverted order.

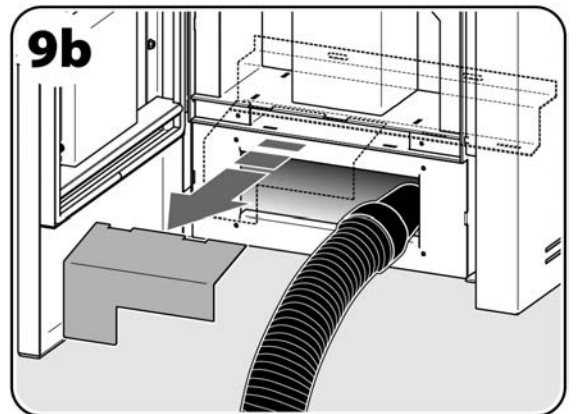

4.2.2 Routine maintenance of type C

To be done at the end of the heating season or when the appliance reaches 2000 hours of operation when the SERVICE message appears, in addition to the recurrent maintenance work type A and to the routine maintenance work type B.

i The routine maintenance of type C shall be performed in order to clean the smoke exhauster [Q] and its housing and to facilitate the cleaning of the lower part of the heat exchanger. This maintenance work is to be completed on both sides of the appliance after removing the external lining.

! CAUTION: The following operation should be performed by a qualified service technician who will assess the need to remove the smoke extractor to clean it.

! WARNING: All cleaning of the various parts must be done when the appliance is completely cold and disconnected from the electrical power source (electrical plug disconnected).

! CAUTION: For safety reasons, before cleaning the appliance make sure the ashes have cooled completely and then remove them with a vacuum cleaner.

i The smoke exhauster [Q] cannot be detached from the unit to which it is connected by an electric wire; to perform the following maintenance works, carefully lay it sideways.

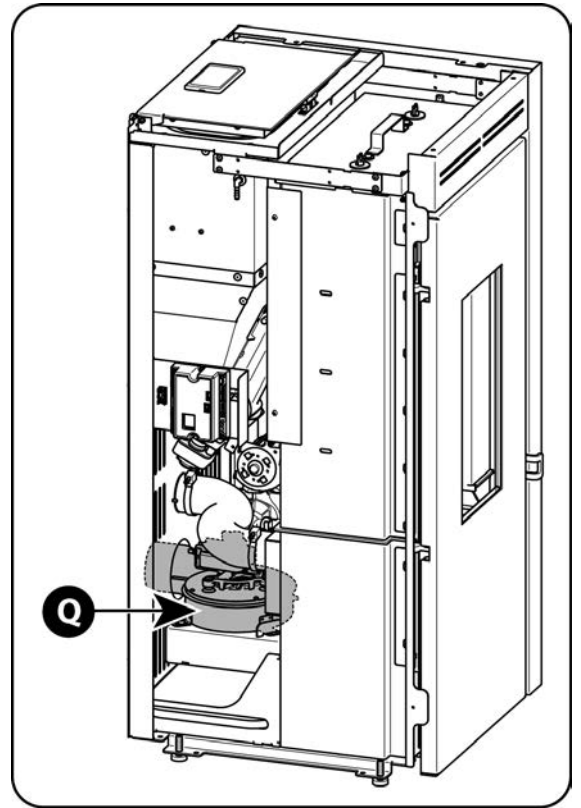

4.2.3 Gasket control

At the end of the heating season, during the routine maintenance of type C, have the qualified technician check the integrity of the gasket sealing the door and of all the removable parts.

They should be replaced once every one or two or three years, depending on the type of appliance and mostly on the operation duration. In order to ensure an air-tight assembly the gaskets should maintain their characteristics of elasticity; as soon as they harden they need to be replaced.

! IMPORTANT: Gasket control is much more important in certified airtight appliances installed in low energy households because the combustion chamber must always be airtight.

4.2.4 Cleaning of vertical venting pipes

Even with the best appliances and chimneys the formation of creosote deposits is unavoidable. Therefore it is necessary to clean the chimney and the vertical venting pipes regularly in order to avoid or reduce them.

Cleaning is recommended at least once a year and even more often if the appliance is used daily and fuel with features different from those illustrated in section 1.4 is employed.

We recommend to let the cleaning process being realized by a professional chimney sweeper, ask the address to your dealer.

The sweeper's intervention may represent an effective and economic solution to protect the installation from corrosion and keep it in efficiency to grant those essential safety conditions that allow us to live with more serenity.

i Just before the beginning of the next season, particularly as regards unoccupied houses, we recommend checking the smoke channel and the chimney, in order to be sure that there is no clogging due to insects, birds or small mammals' nests.}

4.3 Putting your appliance out of service

When the appliance is not going to be used for a long time, usually at the end of the heating season, beside the routine maintenance procedures we recommend that you operate the appliance until the fuel is finished.



IMPORTANT: Unplug the appliance once you have finished using it for the season.

4.4 Failures/ Causes / Trouble-shooting

There is no power to the appliance (led indicator off):

- The power cord may have been damaged or disconnected from the plug.
- The fuse located inside the electronic control unit could be blown (see section 4.4.1).

The appliance fails to start repeatedly:

- The door gaskets could be in bad condition.
- The combustion chamber may have not been submitted to the required routine maintenance works (see section 4.1.3).
- The ignition resistance or the smoke temperature sensor may be blown (have the service staff check the appliance).

Pellets build up in the burn pot and spill out:

- The door gaskets could be in bad condition.
- The burn grate may be clogged (see section 4.1.3, figure 3).
- The appliance may have not been submitted to the required routine maintenance works (see sections 4.1.3 and 4.2).
- There is insufficient combustion air (if the problem persists even after the appliance cleaning, have the service staff check the appliance).
- The smoke exhauster may not be working correctly (in this case have the service staff check the appliance).
- The fuel may be damp.
- The combustion air inlet may be obstructed.
- The present parameter may be unsuitable (see section 3.3.7).

There is smoke in the room:

- Check to see if the gaskets are in good condition.
- In the same room there could be another appliance working (stove, fireplace, wood cooker, suction hood) or not (open fireplace) whose draught may negatively affect that of your appliance or the reverse.
- The appliance may have not been submitted to the required routine maintenance works (see sections 4.1.3 and 4.2).
- Check to see if the exhaust system (pipe and chimney flue) is air-tight or needs to be cleaned out.
- Make sure that there is a good connection between the appliance and the chimney flue.
- The size of the chimney flue does not comply with the requirements in this manual (see sections 2.3.3 and 2.3.4).
- The first times the appliance is operated, the paint on the metal surfaces releases some smells. Simply aerate the room as necessary.
- Check to see if any impediment (plants, buildings) exceeds the height of the chimney cap thus preventing the smoke discharge.
- The draught in the chimney flue may not be adequate.

4.4.1 Replacement of fuse in service

If you press the switch at the back of the unit to the stand-by position and neither the switch light nor the display screen on the control panel will light up, check the fuse in service and if necessary make use of the replacement fuse.



WARNING: This work can only be done after the appliance has cooled completely and has been disconnected from the electrical power source (electrical plug disconnected).

To replace the service fuse, which is located at the rear of the appliance on the side of the power connector, open the fuse box with a screwdriver and remove it, checking the integrity of the service fuse filament [S], and replace if necessary.

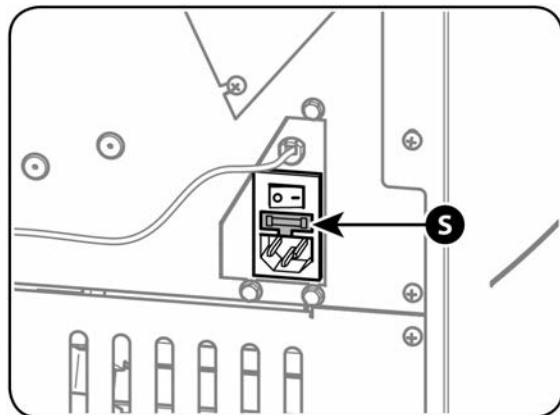

Then plug in the power cord and press the main on/off switch again.

If the problem persists or the fuse should blow again, contact Customer Service.

Fuse Specifications: "5A T 5x20 (delay-fuse)".

5 FOR THE AUTHORIZED SERVICE TECHNICIAN

5.1 Wiring-diagram



WARNING: Even after being switched off, the appliance is not disconnected from electrical power; therefore, before removing the cladding or the back panel and/or the screws holding the electronic control unit, always be sure to first unplug the power cord or turn off the circuit breaker.

PRACTICAL SCHEME LEGEND

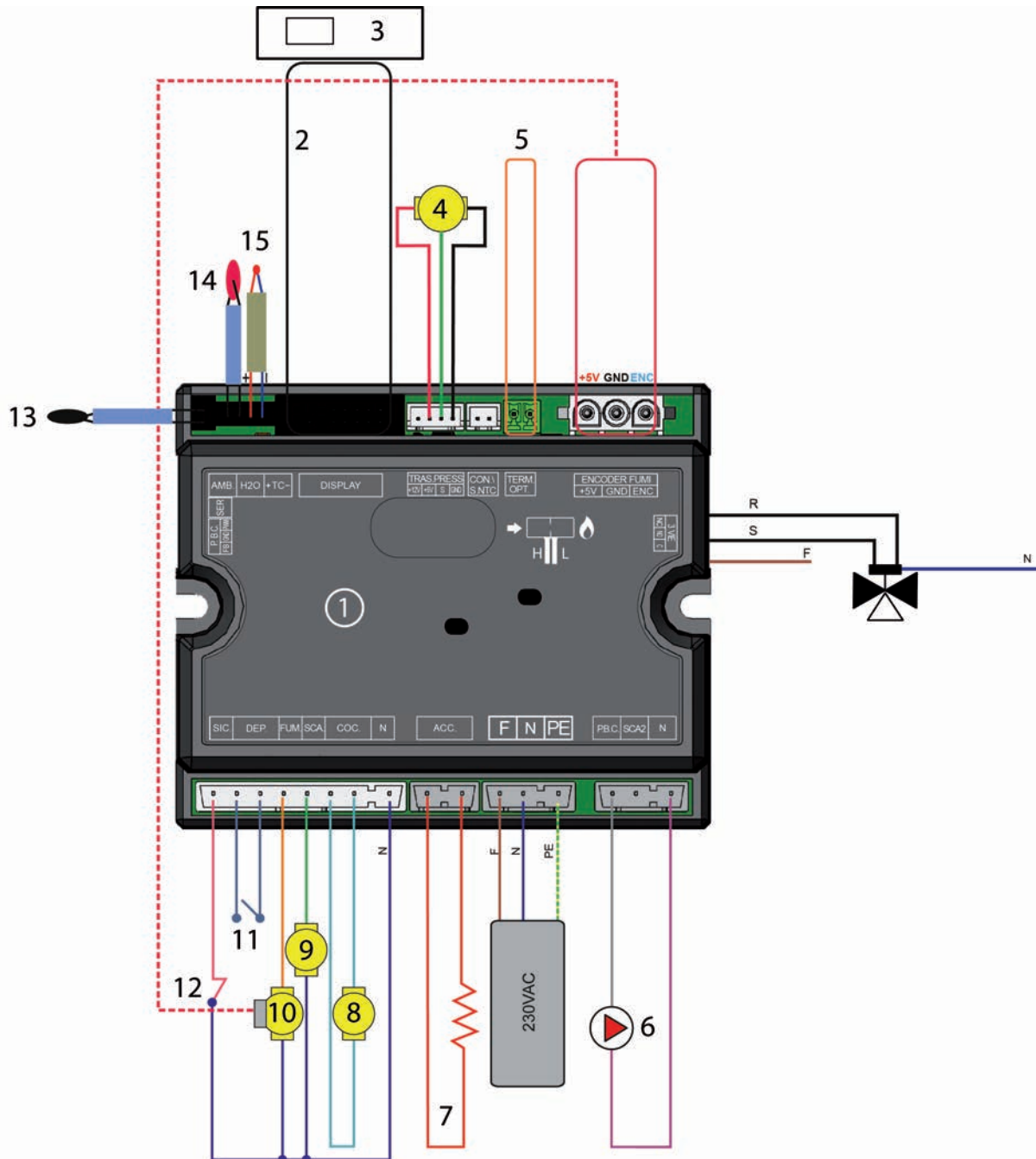

- | | | |
|---|------------------------|-------------------------------------|
| 1. Electronic card | 6. Circulation pump | 11. Depressimeter |
| 2. Control panel wiring | 7. Ignition resistance | 12. Blocking thermostat |
| 3. Control panel | 8. Screw auger geared | 13. Room temperature sensor |
| 4. H ₂ O pressure transducer | 9. Tangential fan | 14. H ₂ O delivery probe |
| 5. External contact | 10. Smoke exhauster | 15. Smoke sensor |

5.1.1 Terminal block for output devices

The electronic control unit is equipped with a 3-way (3WAY) outlet with a terminal block already connected or available in the equipment supplied, for connecting to any pumps.

Free contact: normally open (C-NO) or normally closed (C-NC).

The electrical connections to the control unit must be carefully examined by a qualified technician, who will take into account the type of heating system to which the appliance will be connected.

A "double insulated" power cord must be used to connect to the terminal block, and this cord must also be secured to the back access hole with a suitable power cord holder.

The 3-way outlet is activated when the flow water temperature exceeds the circulation pump starting temperature by 5°C.

5.2 Connection to a thermostat or to a switch

The appliance can be switched on and off by using a clean contact from a thermostat or an external switch connected to the appropriate terminal labelled with the initials "TA" located on the back of the appliance and setting the ambient temperature at below 6°C (see section 3.3.4).

The status of the clean contact is shown on the display by [Toff], indicating contact opened, and [Ton], indicating contact closed.

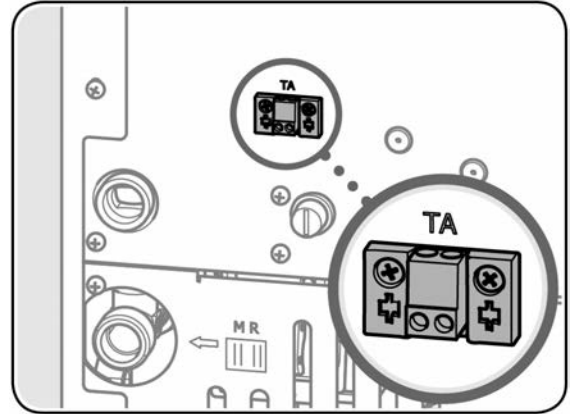

5.3 Spare parts list

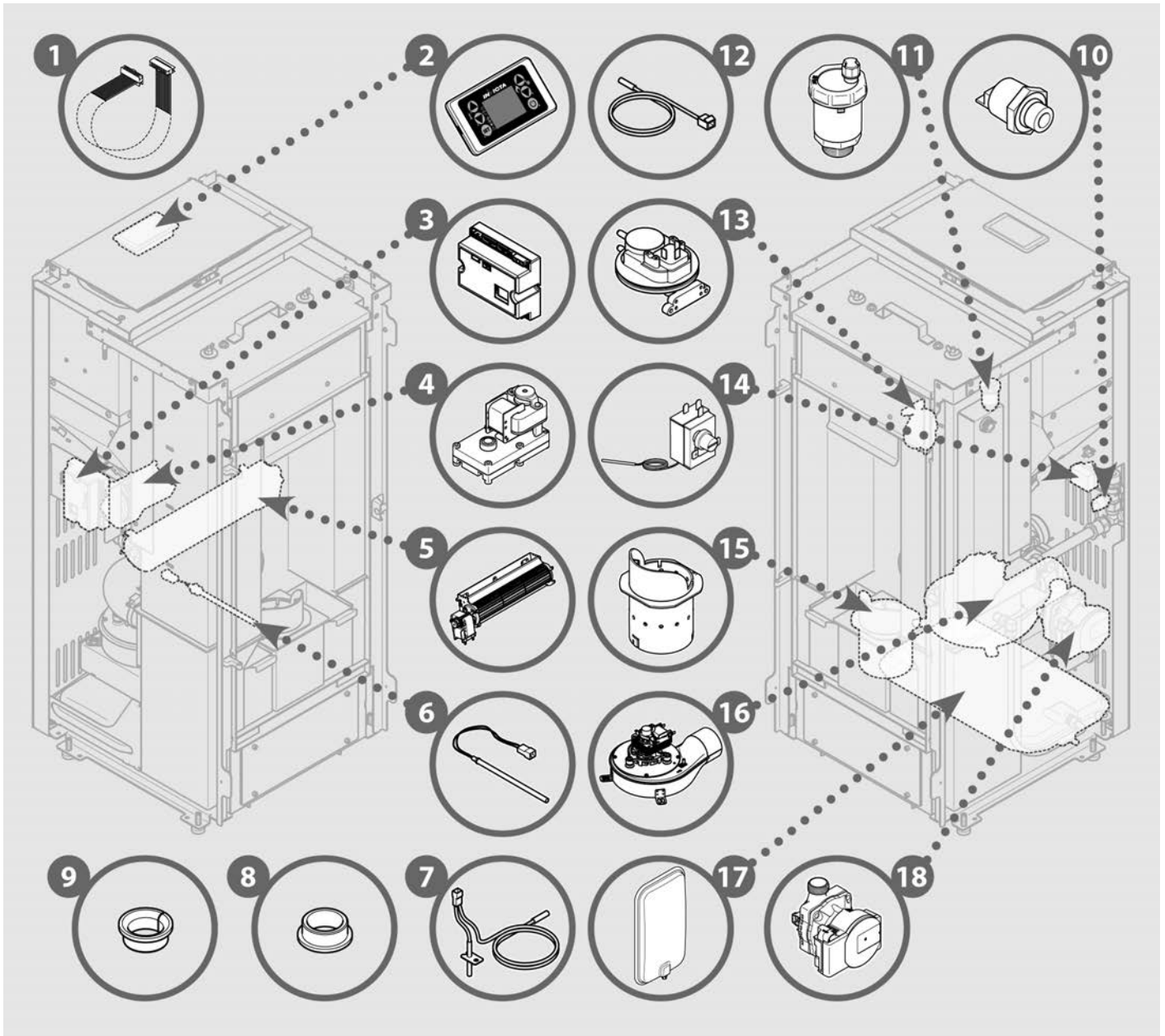

- | | |
|--|---|
| 1. 1043030700 - Flat cable elect.card/security board | 13. 1042200700 - Pressure controller |
| 2. 1046202400I - Control panel | 14. 1042002000 - Blocking thermostat |
| 3. 1041004800 - Neutral electronic card | 15. 1184096110 - Cast iron burn pot |
| 4. 1044003000 - Screw auger geared motor | 16. 1184046410 - Smoke exhauster |
| 5. 1040021300 - Convection fan | 17. 1053000500 - Expansion tank |
| 6. 1049200300 - Ignition resistance | 18. 1051000500 - Circulation pump |
| 7. 1042004800 - Smoke sensor + H2O probe | 00. 1251114300 - Ceramic glass |
| 8. 1010009200 - Teflon bearing | 00. 1090400210 - Ceramic glass gasket |
| 9. 1010009000 - Bearing | 00. 1090104710 - Door gasket |
| 10. 1042200600 - Pressure transducer | 00. 1090812709 - Smoke box gasket |
| 11. 1052100100 - Air vent valve | 00. 1090300110 - Smoke exhauster gasket |
| 12. 1042003500 - Room temperature sensor | |

5.4 Servicing record

| | |
|---|---|
| 1 | 3 |
| | |
| 2 | |
| | |

| | |
|---|---|
| 1 | 3 |
| | |
| 2 | |
| | |

| | |
|---|---|
| 1 | 3 |
| | |
| 2 | |
| | |

| | |
|---|---|
| 1 | 3 |
| | |
| 2 | |
| | |

| | |
|---|---|
| 1 | 3 |
| | |
| 2 | |
| | |

| | |
|---|---|
| 1 | 3 |
| | |
| 2 | |
| | |

1. DATE
2. SIGNATURE OF SERVICING STAFF
3. SERVICING DESCRIPTION

- BLANK LEAF -

- BLANK LEAF -

The Company reserves the right to make any alterations resulting from any technical or commercial reasons it considers appropriate without notice and assumes no responsibility for any possible mistake or inaccuracies in this brochure. The reproduction in whole or in part of the photographs, drawings or texts is forbidden. Infringements will be punished by law. Data and measurements are provided purely as an indication.



Zone Industrielle Lieu-dit « La Gravette »
08350 DONCHERY – Francia
Tel. +33 0324 277171